

Pin Type Hydraulic Flange Spreaders

▼ Shown: FS-56



- Lightweight, ergonomic design for ease of use
- Adjustable jaw widths from 2.75" to 8.50" for a wide range of applications
- Single-acting, spring return RC Series cylinders for fast trouble-free operation

FS Series



Capacity:
5-10 tons

Maximum Operating Pressure:
10,000 psi

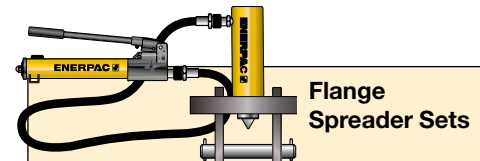

Flange Spreader Sets

Both Hydraulic Flange Spreaders are available as sets (includes pump, tool, gauge, adaptor and hose).

Set Model Number	Spreader Model Number	Pump Model Number
STF-56H	FS-56	P-142
STF-109H	FS-109	P-392
STF-109A	FS-109	PATG-1102N



Wedge Spreaders

Friction-free, smooth and parallel wedge movement with unique interlock wedge design. Eliminates flange damage and risk of spreading arm failure.

Page: 219

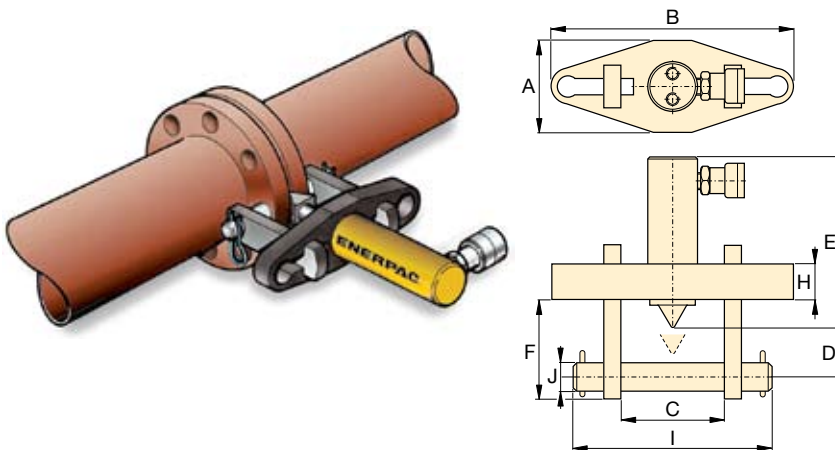

Flange Spreader Matching Chart

ASA Rating (psi)	Pipe Size (in)	
	FS-56	FS-109
150	5-20	22-42
300	2.50-14	16-28
400	2.50-12	14-24
500	2.50-10	12-20
900	.50-6	8-16
1500	.50-3.50	4-8
2500	.50-2.50	3-4

Maximum Flange Thickness (in)	Stud Size (in)	Standard Wedge (in)	Cap. (ton)	Stroke (in)	Oil Cap. (in ³)	Model Number	Dimensions (in)										Weight (lbs)
							A	B	C		D	E	F	H	I	J	
									Min.	Max.							
2 x 2.25	.75-1.13	.13-1.13	5	1.50	1.50	FS-56	3.00	8.25	2.75	6.10	1.28	7.71	3.45	1.00	8.10	.75	26
2 x 3.63	1.25-1.63	.13-1.13	10	2.13	4.80	FS-109	4.25	11.00	4.10	8.50	1.98	6.00	4.50	1.50	10.75	1.25	40