

Air Hydraulic Pumps

▼ Shown: **PAM-1041**

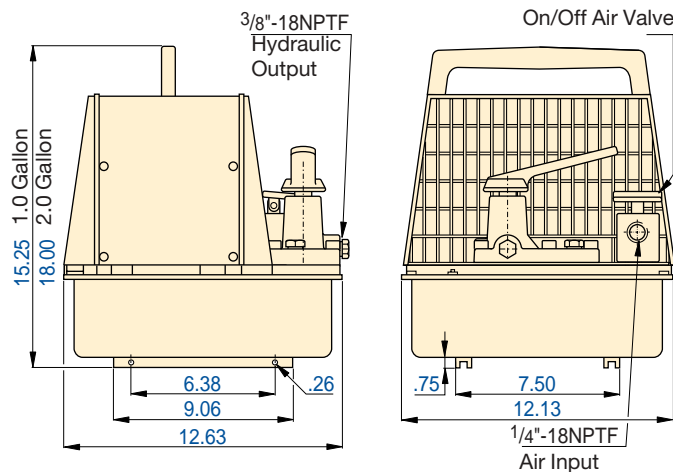

- Twin air motor configuration delivers high-flow performance in first stage, up to 200 psi, for rapid cylinder advance
- 1 and 2 gallon reservoirs for use with a wide range of cylinders
- Integral shroud protects air motors and provides easy portability



PAM-1022

Used with Cylinder	Usable Oil Capacity (gal)	Model Number (with Shroud)	Pressure Rating (psi)	Output Flow Rate (in ³ /min)		Valve Function	Valve Model	Air Pressure Range* (psi)	Air Consumption (scfm)	Sound Level (dBA)	Weight (lbs)
				1 st stage	2 nd stage						
Single-acting	0.7	PAM-1021	10,000	650	9	Adv/Hold/Ret	VM-2	60-120	18	87	50
	2.0	PAM-1022	10,000	650	9	Adv/Hold/Ret	VM-2	60-120	18	87	60
Double-acting	0.7	PAM-1041	10,000	650	9	Adv/Hold/Ret	VM-4	60-120	18	87	50
	2.0	PAM-1042	10,000	650	9	Adv/Hold/Ret	VM-4	60-120	18	87	60

* Recommended Regulator-Filter-Lubricator: RFL-102

PAM Series

Reservoir Capacity:
1.0-2.0 gal.

Flow at Rated Pressure:
9 in³/min.

Maximum Operating Pressure:
10,000 psi



Locking Valves

Pumps with VM-4 manual valves are available with VM-4L manual locking valves instead. Add suffix "L" to pump model number.

Page: **130**



VA-2 Remote Valve

For remote operation of PAM-10 series air pumps. Permits either hand or foot operation.

