

▼ Shown: ZA4208MX, ZA4420MX



Z Tough. Dependable. Innovative. Z-CLASS

- Features Z-Class high efficiency pump design, higher oil flow and bypass pressure
- Two-speed operation and high by-pass pressure reduces cycle time for improved productivity
- Internal relief valves. One is factory set for overload protection while the second is user adjustable for pre-setting maximum system pressure
- Sight gauge on 1 and 2 gallon and level gauge on 2.5, 5 and 10 gallon reservoirs allow quick and easy oil level monitoring
- Optional heat exchanger warms exhaust air to prevent freezing and cools the oil

i ATEX Certified
See explanation of ATEX certification in the “Yellow Pages”.

Ex II 2 GD ck T4

Page: 103

i Speed Chart
To determine how a ZA Series pump will operate your cylinder, see the Pump/Cylinder Speed Chart in the “Yellow Pages”.

Page: 113

Hoses
Enerpac offers a complete line of high-quality hydraulic hoses. To ensure the integrity of your system, specify only genuine Enerpac hydraulic hoses.

Page: 116

ZA4 Performance		
Dynamic Air Pressure Range	Air Consumption	Sound Level
(psi)	(scfm)	(dBA)
60-100	20-100	85-90

Used with Cylinder	Usable Oil Capacity (gal)	Valve Model Number ²⁾	Valve Function	Model Number	Output Flow Rate ¹⁾			
					(in ³ /min)			
					100 psi	700 psi	5,000 psi	10,000 psi
Single-acting	1.0	Manual VM32	Advance/Retract	ZA4204MX	850	675	110	80
	2.0			ZA4208MX	850	675	110	80
	5.0			ZA4220MX	850	675	110	80
Double-acting	1.0	Manual VM43	Advance/Hold/Retract	ZA4404MX	850	675	110	80
	2.0			ZA4408MX	850	675	110	80
	2.5			ZA4410MX	850	675	110	80
	5.0			ZA4420MX	850	675	110	80
	10.0			ZA4440MX	850	675	110	80

1) Actual flow will vary with air supply
2) See valve section for hydraulic symbols and details

ZA-Series Air Hydraulic Pump Ordering Matrix

CUSTOM BUILD YOUR ZA4 AIR PUMP

▼ This is how a ZA-Series Pump model number is built up:



1	2	3	4	5	6	7	8	8	8	8
Product Type	Motor Type	Flow Group	Valve Type	Usable oil capacity	Valve Operation	Voltage	Options	Options	Options	Options

1 Product Type

Z = Pump class

2 Motor Type

A = Air motor

3 Flow Group

4 = 80 in³/min@10,000 psi

4 Valve Type

0 = No valve with coverplate
 2 = 3-way, 2-position (VM32)
 3 = 3-way, 3-position (VM33)
 4 = 4-way, 3-position (VM43)
 6 = 3-way, 3-position, locking (VM33L)
 8 = 4-way, 3-position, locking (VM43L)

5 Usable Oil Capacity

04 = 1.0 gallon
 08 = 2.0 gallon
 10 = 2.5 gallon
 20 = 5.0 gallon
 40 = 10.0 gallon

6 Valve Operation

M = Manual valve
 N = No valve

7 Voltage

X = Not applicable

8 Options

(Specify in alphabetical order)

F = Filter
 G = 0-15,000 psi gauge (2 1/2")
 H = Heat exchanger
 K = Skidbar (1 and 2 gallon reservoirs only)
 N = No reservoir handles (includes lifting eyes; 2.5, 5, 10 gallon only)
 R = Roll bars

Ordering Example

Model Number: ZA4208MX-FHK

ZA4208MX-FHK is an air operated pump with a 3-way, 2-position manual valve, a 2.0 gallon reservoir, filter, heat exchanger and skid bar.

ZA4 Series



Reservoir Capacity:

1.0-10.0 gal.

Flow at Rated Pressure:

80 in³/min.

Maximum Operating Pressure:

10,000 psi

- ① User adjustable relief valve on all manual valves
- ② Air inlet 1/2" NPTF
- ③ Return Line Filter (optional)
- ④ Oil Sight Gauge
- ⑤ Roll Bar (optional)
- ⑥ Oil Drain
- ⑦ Skid Bar (model no. SBZ-4) (optional)

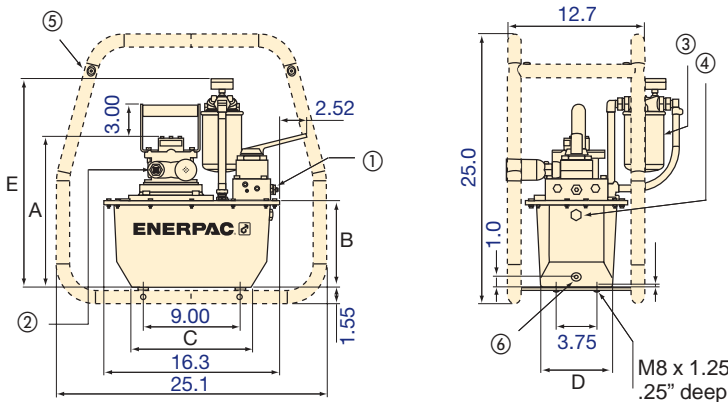

1 and 2 gallon reservoirs

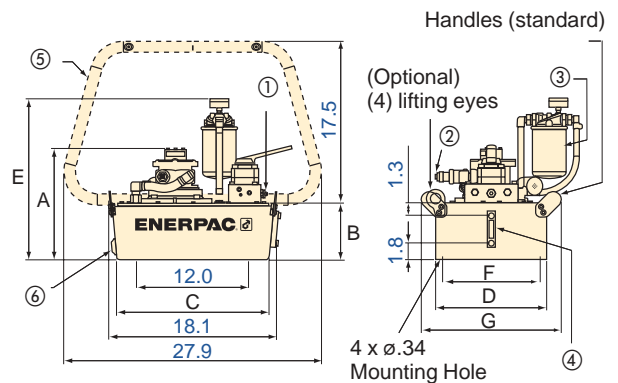

2.5, 5, 10 gallon reservoirs

Dimensions (in)							Weight (incl. oil) (lbs)
A	B	C	D	E	F	G	
11.6	5.6	11.0	6.0	16.9	-	-	65.5
14.0	8.0	11.3	6.6	19.3	-	-	75.7
13.0	7.1	16.3	16.6	15.6	15.6	18.4	112.7
11.6	5.6	11.0	6.0	16.9	-	-	66.7
14.0	8.0	11.3	6.6	19.3	-	-	76.9
12.0	6.1	16.5	12.0	17.4	11.0	15.1	87.1
13.0	7.1	16.3	16.6	15.6	15.6	18.4	113.9
16.5	10.6	15.7	19.9	21.9	18.9	23.0	164.6

