

L1511 Rev. A 08/06

Repair Parts Sheets for this product are available from the Enerpac web site at [www.enerpac.com](http://www.enerpac.com), or from your nearest Authorized Enerpac Service Center or Enerpac Sales office.

#### 1.0 IMPORTANT RECEIVING INSTRUCTIONS

Visually inspect all components for shipping damage. Shipping damage is **not** covered by warranty. If shipping damage is found, notify carrier at once. The carrier is responsible for all repair and replacement costs resulting from damage in shipment.

#### SAFETY FIRST

#### 2.0 SAFETY ISSUES



Read all instructions, warnings and cautions carefully. Follow all safety precautions to avoid personal injury or property damage during system operation. Enerpac cannot be responsible for damage or injury resulting from unsafe product use, lack of maintenance or incorrect product and/or system operation. Contact Enerpac when in doubt as to the safety precautions and operations. If you have never been trained on high-pressure hydraulic safety, consult your distribution or service center for a free Enerpac Hydraulic safety course.

Failure to comply with the following cautions and warnings could cause equipment damage and personal injury.

A **CAUTION** is used to indicate correct operating or maintenance procedures and practices to prevent damage to, or destruction of equipment or other property.

A **WARNING** indicates a potential danger that requires correct procedures or practices to avoid personal injury.

A **DANGER** is only used when your action or lack of action may cause serious injury or even death.



**WARNING:** Wear proper personal protective gear when operating hydraulic equipment.



**WARNING: Stay clear of loads supported by hydraulics.** A cylinder, when used as a load lifting device, should never be used as a load holding device. After the load has been raised or lowered, it must always be blocked mechanically.



**WARNING: USE ONLY RIGID PIECES TO HOLD LOADS.** Carefully select steel or wood blocks that are capable of supporting the load. Never use a hydraulic cylinder as a shim or spacer in any lifting or pressing application.



**DANGER:** To avoid personal injury keep hands and feet away from cylinder and workpiece during operation.



**WARNING:** Do not exceed equipment ratings. Never attempt to lift a load weighing more than the capacity of the cylinder. Overloading causes equipment failure and possible personal injury. The cylinders are designed for a max. pressure of 700 bar [10,000 psi]. Do not connect a jack or cylinder to a pump with a higher pressure rating.



**Never** set the relief valve to a higher pressure than the maximum rated pressure of the pump. Higher settings may result in equipment damage and/or personal injury.



**WARNING:** The system operating pressure must not exceed the pressure rating of the lowest rated component in the system. Install pressure gauges in the system to monitor operating pressure. It is your window to what is happening in the system.



**CAUTION:** Avoid damaging hydraulic hose. Avoid sharp bends and kinks when routing hydraulic hoses. Using a bent or kinked hose will cause severe back-pressure. Sharp bends and kinks will internally damage the hose leading to premature hose failure.



**Do not** drop heavy objects on hose. A sharp impact may cause internal damage to hose wire strands. Applying pressure to a damaged hose may cause it to rupture.



**IMPORTANT:** Do not lift hydraulic equipment by the hoses or swivel couplers. Use the carrying handle or other means of safe transport.





**CAUTION: Keep hydraulic equipment away from flames and heat.** Excessive heat will soften packings and seals, resulting in fluid leaks. Heat also weakens hose materials and packings. For optimum performance do not expose equipment to temperatures of 65°C [150°F] or higher. Protect hoses and cylinders from weld spatter.





**DANGER: Do not handle pressurized hoses.** Escaping oil under pressure can penetrate the skin, causing serious injury. If oil is injected under the skin, see a doctor immediately.

 **WARNING:** Only use hydraulic cylinders in a coupled system. Never use a cylinder with unconnected couplers. If the cylinder becomes extremely overloaded, components can fail catastrophically causing severe personal injury.

 **WARNING: BE SURE SETUP IS STABLE BEFORE LIFTING LOAD.** Cylinders should be placed on a flat surface that can support the load. Where applicable, use a cylinder base for added stability. Do not weld or otherwise modify the cylinder to attach a base or other support.

 **Avoid** situations where loads are not directly centered on the cylinder plunger. Off-center loads produce considerable strain on cylinders and plungers. In addition, the load may slip or fall, causing potentially dangerous results.

 Distribute the load evenly across the entire saddle surface. Always use a saddle to protect the plunger.

 **IMPORTANT:** Hydraulic equipment must only be serviced by a qualified hydraulic technician. For repair service, contact the Authorized ENERPAC Service Center in your area. To protect your warranty, use only ENERPAC oil.

 **WARNING:** Immediately replace worn or damaged parts by genuine ENERPAC parts. Standard grade parts will break causing personal injury and property damage. ENERPAC parts are designed to fit properly and withstand high loads.

Flange Spreader Selection Chart											
Model No.	Pump	Hose	Cylinder	Crossbar	Side Plate	Pin	Lock Pin	Adaptor	1/8 – 1 1/8" Wedge	1 3/16 – 2 3/16" Wedge	Wt. Lb.
FS-56	—	—	RC-53ST	F56-2	(2) F56-3	F56-4	(2) F109-8	F56-5	F109-6	F109-7 (optional)	26
FS-56S	P-142	HC-882	RC-53ST	F56-2	(2) F56-3	F56-4	(2) F109-8	F56-5	F109-6	F109-7 (optional)	34
FS-109	—	—	RC-102	F109-2	(2) F109-3	F109-4	(2) F109-8	F109-5	F109-6	F109-7 (optional)	40
FS-109S	P-392	HC-913	RC-102	F109-2	(2) F109-3	F109-4	(2) F109-8	F109-5	F109-6	F109-7 (optional)	52

Metal box included with FS-56, FS-56S, FS-109, FS-109S.

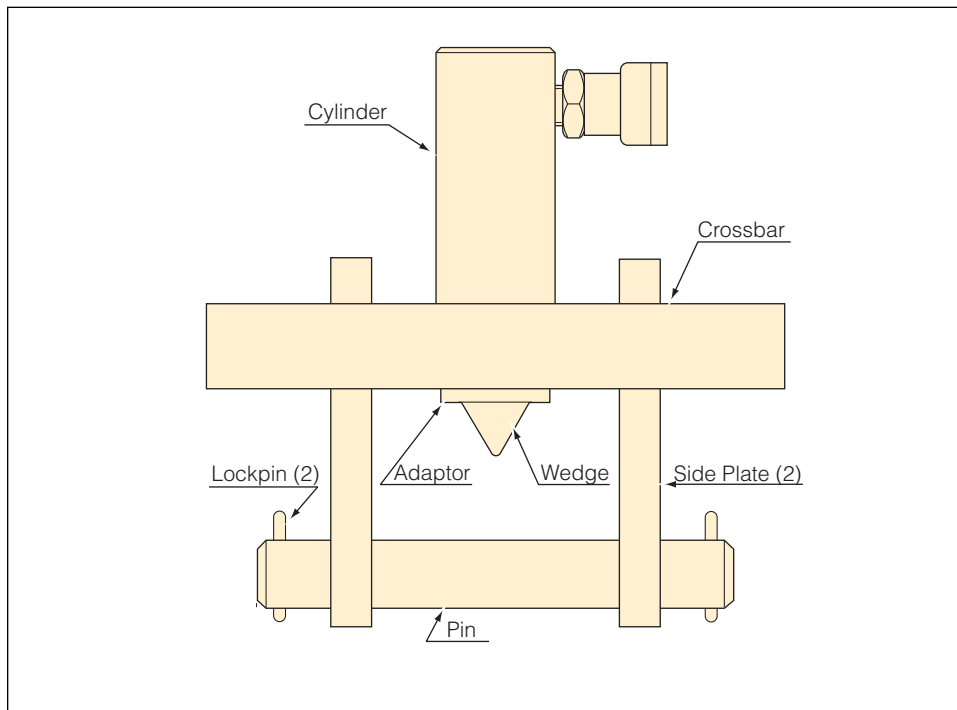
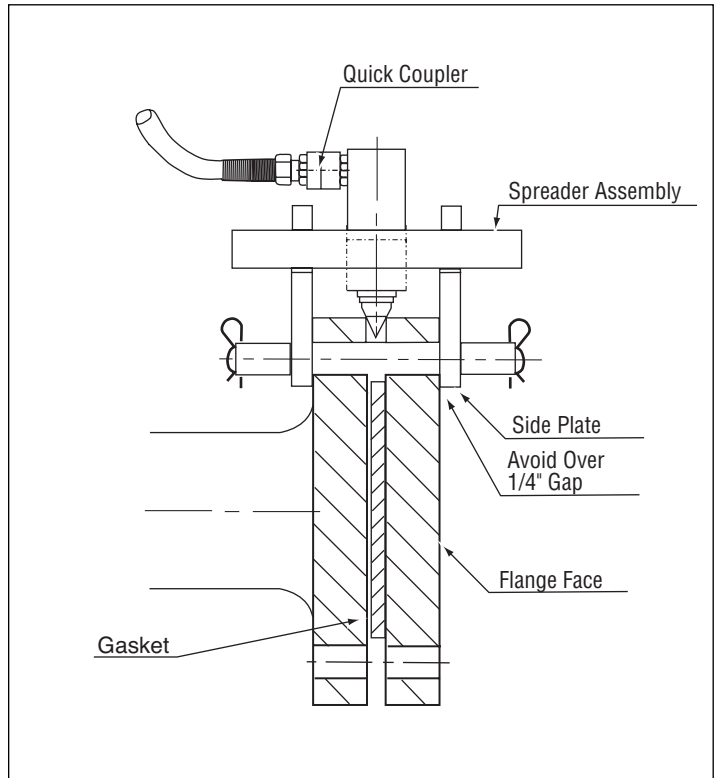

**Figure 1**

## ASSEMBLY INSTRUCTIONS

1. Before assembly, identify all component parts included with the set. Refer to the Flange Spreader Selection Chart for identification of the component parts and to Figure 1 to aid in the assembly procedure.
2. Hand tighten the hydraulic cylinder into the crossbar making sure the cylinder collar threads are fully engaged. (For cylinder RC-102, first remove thread protector.)
3. Thread the adaptor (F56-5 or F109-5) into the end of the cylinder plunger until fully engaged, hand tighten only.
4. Thread the wedge provided (or the optional wedge, if desired) into the adaptor until fully engaged, hand tighten only.
5. Insert the small head of one of the side plates through the slot in one end of the crossbar and rotate 90°. Repeat this procedure for the other side plate into the slot at the opposite end of the crossbar. The spreader is now ready to be slipped onto the flange.
6. Connect the hose assembly to the proper port on your pump. Use Teflon tape on the pipe threads and tighten with a wrench.

**IMPORTANT NOTE:** Teflon tape is an excellent thread sealer. However, if the tape is not properly applied, pieces may enter the hydraulic system causing malfunctions and component damage. Use 1-1/2 wraps of tape on each connection, leaving the starting thread free of tape. Cut off all loose tape ends.



**Figure 2**

4. Apply light pressure with the hand pump and check that all connections fit securely. If so, proceed with the flange spreading operation. If not, make needed adjustments before proceeding.

**NOTE:** A light coating of grease on the wedge tapers will make it easier for the wedge to be forced between the flange faces.

**CAUTION:** Do not force the wedge between the flange faces beyond the maximum width of the tapered sides of the wedge or binding may occur.

5. If two flange spreaders are to be used to perform the task, they should be positioned 180° apart.
6. To remove the wedge, open the release valve of the hand pump. If the wedge binds, work the cylinder back and forth to help walk the wedge out of the gap.

Refer to chart below for matching flange spreaders to pipe sizes and ASA ratings.

Flange Spreader Matching Chart		
ASA Rating (psi)	Pipe Size (inches)	
	FS-56	FS-109
150	5 - 20	22 - 42
300	2 1/2 - 14	16 - 28
400	2 1/2 - 12	14 - 24
500	2 1/2 - 10	12 - 20
900	1 1/2 - 6	8 - 16
1500	1 1/2 - 3 1/2	4 - 8
2500	1 1/2 - 2 1/2	3 - 4



**WARNING:** If an Enerpac pump is not used, be sure your pump does not exceed the rated capacity of the flange spreader. Failure to do so could result in personal injury or property damage.

## OPERATING INSTRUCTIONS

**IMPORTANT NOTE:** Prepare the flange by loosening all the bolts and removing one bolt for the insertion of the flange spreader pin. Removal of the remaining bolts may be necessary depending on your flange maintenance application. In some cases, leaving one or two loosened bolts in the flange may be helpful for realignment of the flange halves. Qualified personnel should determine the proper method of preparation.

1. Slip the assembled spreader onto the flange. Align the holes in the side plates with the flange bolt holes and insert the pin through the side plates and bolt holes as shown in Figure B. Insert the lockpins. Keep the side plates, pin and crossbar centered on the flange.
2. Rotate the wedge clockwise allowing the tapered sides to be forced between the flange faces. If the wedge cannot be rotated sufficiently in a clockwise direction for proper alignment, then rotate it counter-clockwise just enough to align it with the flange. See Figure 2.



**WARNING:** Keep side plates close to flange face while applying pressure. Exceeding 1/4 inch distance between side plate and flange face could result in personal injury or property damage.

3. Connect the quick coupler on the hose to the quick coupler on the cylinder and hand tighten.

## Enerpac Worldwide Locations

**Africa**  
ENERPAC Middle East FZE  
P.O. Box 18004  
Jebel Ali, Dubai  
United Arab Emirates  
Tel: +971 (0)4 8872686  
Fax: +971 (0)4 8872687

**Australia**  
Actuant Australia Ltd.  
Block V Unit 3  
Regents Park Estate  
391 Park Road  
Regents Park NSW 2143  
(P.O. Box 261) Australia  
Tel: +61 297 438 988  
Fax: +61 297 438 648

**Brazil**  
Power Packer do Brasil Ltda.  
Rua dos Inocentes, 587  
04764-050 - Sao Paulo (SP)  
Tel: +55 11 5687 2211  
Fax: +55 11 5686 5583  
**Toll Free in Brazil:**  
Tel: 0800 891 5770  
vendabrasil@enerpac.com

**Canada**  
Actuant Canada Corporation  
6615 Ordan Drive, Unit 14-15  
Mississauga, Ontario L5T 1X2  
Tel: +1 905 564 5749  
Fax: +1 905 564 0305  
**Toll Free:**  
Tel: +1 800 268 4987  
Fax: +1 800 461 2456

**Technical Inquiries:**  
techservices@enerpac.com

**China**  
Actuant China Ltd.  
1F, 269 Fute N. Road  
Waigaoqiao Free Trade Zone  
Pudong New District  
Shanghai, 200 131 China  
Tel: +86 21 5866 9099  
Fax: +86 21 5866 7156

◆ e-mail: info@enerpac.com

**Actuant China Ltd. (Beijing)**  
709B Diyang Building  
Xin No. 2  
Dong San Huan North Rd.  
Beijing City  
100028 China  
Tel: +86 10 845 36166  
Fax: +86 10 845 36220

**Central and Eastern Europe, Greece**  
ENERPAC B.V.  
Galvanistraat 115  
P.O. Box 8097  
6710 AB Ede  
The Netherlands  
Tel: +31 318 535 936  
Fax: +31 318 535 951

**France, Switzerland francophone**  
ENERPAC  
Une division de ACTUANT  
France S.A.  
B.P. 200, Parc d'Activités  
du Moulin de Massy  
F-91882 Massy CEDEX France  
Tel: +33 1 60 13 68 68  
Fax: +33 1 69 20 37 50

**Germany, Austria, Greece and Switzerland**  
ENERPAC GmbH  
P.O. Box 300113  
D-40401 Düsseldorf  
Germany  
Tel: +49 211 471 490  
Fax: +49 211 471 49 28

**India**  
ENERPAC Hydraulics  
(India) Pvt. Ltd.  
Office No. 9,10 & 11,  
Plot No. 56, Monarch Plaza,  
Sector 11, C.B.D. Belapur  
Navi Mumbai 400614, India  
Tel: +91 22 2756 6090  
Tel: +91 22 2756 6091  
Fax: +91 22 2756 6095

**Italy**  
ENERPAC S.p.A.  
Via Canova 4  
20094 Corsico (Milano)  
Tel: +39 02 4861 111  
Fax: +39 02 4860 1288

**Japan**  
Applied Power Japan Ltd.  
Besshochou 85-7  
Saitama-shi, Kita-ku,  
Saitama 331-0821  
Japan  
Tel: +81 48 662 4911  
Fax: +81 48 662 4955

**Middle East, Turkey and Caspian Sea**  
ENERPAC Middle East FZE  
P.O. Box 18004  
Jebel Ali, Dubai  
United Arab Emirates  
Tel: +971 (0)4 8872686  
Fax: +971 (0)4 8872687

**Russia and CIS (excl. Caspian Sea Countries)**  
Actuant LLC  
Admiral Makarov Street 8  
125212 Moscow, Russia  
Tel: +7-495-9809091  
Fax: +7-495-9809092

**Singapore**  
Actuant Asia Pte. Ltd.  
25 Serangoon North Ave. 5  
#03-01 Keppel Digihub  
Singapore 554914  
Thomson Road  
P.O. Box 114  
Singapore 915704  
Tel: +65 64 84 5108  
+65 64 84 3737  
Fax: +65 64 84 5669  
**Toll Free:** +1800 363 7722  
**Technical Inquiries:**  
techsupport@enerpac.com.sg

◆ internet: www.enerpac.com

**South Korea**  
Actuant Korea Ltd.  
3Ba 717,  
Shihwa Industrial Complex  
Jungwang-Dong, Shihung-Shi, Kyunggi-Do  
Republic of Korea 429-450  
Tel: +82 31 434 4506  
Fax: +82 31 434 4507

**Spain and Portugal**  
ENERPAC  
C/San José Artesano 8  
Pol. Ind.  
28108 Alcobendas  
(Madrid) Spain  
Tel: +34 91 661 11 25  
Fax: +34 91 661 47 89

**The Netherlands, Belgium, Luxembourg, Sweden, Denmark, Norway, Finland and Baltic States**  
ENERPAC B.V.  
Galvanistraat 115  
P.O. Box 8097, 6710 AB Ede  
The Netherlands  
Tel: +31 318 535 911  
Fax: +31 318 525 613  
+31 318 535 848

**Technical Inquiries Europe:**  
techsupport.europe@enerpac.com

**United Kingdom, Ireland**  
ENERPAC Ltd.  
Enerpac Ltd  
Bentley Road South  
Darlaston, West Midlands  
WS10 8LQ, United Kingdom  
Tel: +44 (0)121 50 50 787  
Fax: +44 (0)121 50 50 799

**USA, Latin America and Caribbean**  
ENERPAC  
P.O. Box 3241  
6100 N. Baker Road  
Milwaukee, WI 53209 USA  
Tel: +1 262 781 6600  
Fax: +1 262 783 9562

**Inquiries/orders:**  
+1 800 558 0530  
**Technical Inquiries:**  
techservices@enerpac.com

All Enerpac products are guaranteed against defects in workmanship and materials for as long as you own them.  
For your nearest authorized Enerpac Service Center, visit us at [www.enerpac.com](http://www.enerpac.com)