

L1606 Rev. B 03/03

Repair Parts Sheets for this product are available from the Enerpac web site at www.enerpac.com, or from your nearest Authorized Enerpac Service Center or Enerpac Sales office.

1.0 IMPORTANT RECEIVING INSTRUCTIONS

Visually inspect all components for shipping damage. Shipping damage is **not** covered by warranty. If shipping damage is found, notify carrier at once. The carrier is responsible for all repair and replacement costs resulting from damage in shipment.

SAFETY FIRST

2.0 SAFETY ISSUES



Read all instructions, warnings and cautions carefully. Follow all safety precautions to avoid personal injury or property damage during system operation. Enerpac cannot be responsible for damage or injury resulting from unsafe product use, lack of maintenance or incorrect product and/or system operation. Contact Enerpac when in doubt as to the safety precautions and operations. If you have never been trained on high-pressure hydraulic safety, consult your distribution or service center for a free Enerpac Hydraulic safety course.

Failure to comply with the following cautions and warnings could cause equipment damage and personal injury.

A **CAUTION** is used to indicate correct operating or maintenance procedures and practices to prevent damage to, or destruction of equipment or other property.

A **WARNING** indicates a potential danger that requires correct procedures or practices to avoid personal injury.

A **DANGER** is only used when your action or lack of action may cause serious injury or even death.



WARNING: Wear proper personal protective gear when operating hydraulic equipment.



WARNING: Stay clear of loads supported by hydraulics. A cylinder, when used as a load lifting device, should never be used as a load holding device.

After the load has been raised or lowered, it must always be blocked mechanically.



WARNING: USE ONLY RIGID PIECES TO HOLD LOADS.

Carefully select steel or wood blocks that are capable of supporting the load. Never use a hydraulic cylinder as a shim or spacer in any lifting or pressing application.



DANGER: To avoid personal injury keep hands and feet away from cylinder and workpiece during operation.



WARNING: Do not exceed equipment ratings. Never attempt to lift a load weighing more than the capacity of the cylinder. Overloading causes equipment failure and possible personal injury. The cylinders are designed for a max. pressure of 700 bar [10,000 psi]. Do not connect a jack or cylinder to a pump with a higher pressure rating.



RFL-102 Regulator-Filter-Lubricator

- Regulates air pressure
- Filter air input
- Lubricates air motors with a fine oil vapor mist
- Maximum air flow 48 scfm



Never set the relief valve to a higher pressure than the maximum rated pressure of the pump. Higher settings may result in equipment damage and/or personal injury.



WARNING: The system operating pressure must not exceed the pressure rating of the lowest rated component in the system. Install pressure gauges in the system to monitor operating pressure. It is your window to what is happening in the system.



CAUTION: Avoid damaging hydraulic hose. Avoid sharp bends and kinks when routing hydraulic hoses. Using a bent or kinked hose will cause severe back-pressure. Sharp bends and kinks will internally damage the hose leading to premature hose failure.



Do not drop heavy objects on hose. A sharp impact may cause internal damage to hose wire strands. Applying pressure to a damaged hose may cause it to rupture.



IMPORTANT: Do not lift hydraulic equipment by the hoses or swivel couplers. Use the carrying handle or other means of safe transport.



CAUTION: Keep hydraulic equipment away from flames and heat. Excessive heat will soften packings and seals, resulting in fluid leaks. Heat also weakens hose materials and packings. For optimum performance do not expose equipment to temperatures of 65°C [150°F] or higher. Protect hoses and cylinders from weld spatter.



DANGER: Do not handle pressurized hoses. Escaping oil under pressure can penetrate the skin, causing serious injury. If oil is injected under the skin, see a doctor immediately.



WARNING: Only use hydraulic cylinders in a coupled system. Never use a cylinder with unconnected couplers. If the cylinder becomes extremely overloaded, components can fail catastrophically causing severe personal injury.



WARNING: BE SURE SETUP IS STABLE BEFORE LIFTING LOAD. Cylinders should be placed on a flat surface that can support the load. Where applicable, use a cylinder base for added stability. Do not weld or otherwise modify the cylinder to attach a base or other support.



Avoid situations where loads are not directly centered on the cylinder plunger. Off-center loads produce considerable strain on cylinders and plungers. In addition, the load may slip or fall, causing potentially dangerous results.



Distribute the load evenly across the entire saddle surface. Always use a saddle to protect the plunger.



IMPORTANT: Hydraulic equipment must only be serviced by a qualified hydraulic technician. For repair service, contact the Authorized ENERPAC Service Center in your area. To protect your warranty, use only ENERPAC oil.



WARNING: Immediately replace worn or damaged parts by genuine ENERPAC parts. Standard grade parts will break causing personal injury and property damage. ENERPAC parts are designed to fit properly and withstand high loads.

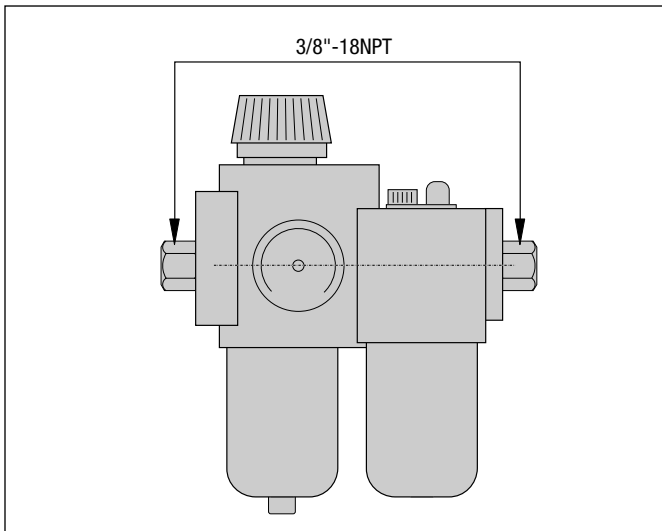

3.0 INSTALLATION INSTRUCTIONS

- DO NOT INSTALL THIS PRODUCT UNTIL YOU HAVE READ THIS ENTIRE PRODUCT INFORMATION SHEET.
Your unit has a polycarbonate bowl, so note the special warnings.
- EXCEPT as otherwise specified by the manufacturer, this product is designed for compressed air service, and use with any other fluid (liquid or gas) is a misapplication. For example, use with, or injection of certain hazardous liquids or gases in the system (such as alcohol or liquid petroleum gas) could be harmful to the unit or result in a combustible condition or hazardous external leakage. Before using with fluids other than air, or for non-industrial applications, or for life support systems, consult manufacturer for written approval. Maximum temperature and pressure ratings for polycarbonate bowls are 125 degrees Fahrenheit (52 degrees Celsius) and 150 PSIG (10.3 Bar).

- INSTALL as close as possible to point where air is being used
- INSTALL unit with air flowing through the body in direction indicated by arrow.
- INSTALL unit ahead of equipment that requires regulated, filtered, lubricated air.
- INSTALL a Regulator/Filter/Lubricator that has the same size as the pipe line on which it will be mounted. Avoid using fittings, couplings, etc. that restrict the air flow.
- INSTALL unit in a vertical position with pressure adjusting handle up.
- OTHER regulated air pressure lines may be run from the other gauge port as well as the outlet port. In addition, the gauge may be moved to the port on the opposite side of the regulator.
- PLUG any unused port.
- To adjust air pressure, turn adjustment knob clockwise to raise the regulated pressure and counterclockwise to lower the regulated pressure.
- FILL lubricator by pouring the oil into the bowl through the fill port. Lubricator can be filled while pressurized.
- USE CLEAN, NONDETERGENT OIL, preferably SAE 10 or lighter. The rate of oil delivery may be controlled by turning the adjusting screw counterclockwise for more, and clockwise for less oil delivered. Once set, the variable orifice in the lubricator will maintain the same ratio of oil to airflow regardless of any change in airflow rate.

4.0 MAINTENANCE INSTRUCTIONS

- DEPRESSURIZE UNIT BEFORE REMOVING GUARD AND/OR BOWL.
- INSPECT BOWL daily to detect crazing, cracking, damage, or deterioration. Immediately replace any crazed, cracked, damaged or deteriorated bowl with a new polycarbonate bowl and metal bowl guard.
- CLEAN FILTER ELEMENT periodically by removing from filter, tapping on hard surface and blowing off with an airgun.
- DRAIN filter bowl at least once per work shift.
- IF BOWL SEAL is crazed, cracked, damaged or deteriorated, replace with manufacturer's approved seal.
- PERIODICALLY REMOVE the adjusting screw and clean the needle and the seat in the body by blowing off with airgun.
- DRAIN OFF any contaminants which may collect in the bottom of the bowl.



CAUTION: YOUR UNIT HAS A POLYCARBONATE PLASTIC BOWL

- DO NOT INSTALL unit with polycarbonate bowl where it will be subject to temperatures higher than 125 degrees Fahrenheit (52 degrees Celsius) or where pressures exceed 150 PSIG (10.3 Bar).
- WHEN BOWL becomes dirty, replace polycarbonate bowl, or wipe clean with dry clean cloth.
- DO NOT use polycarbonate bowl near, or clean bowl with, materials such as alcohol, chloride, alkalis, amines, ketones, esters, aromatic hydrocarbons or other materials included in the list on page 4. Do not subject bowl to oils listed on the chart on page 4.
- DO NOT INSTALL unit with polycarbonate bowl on a compressed air line where the compressor is lubricated with, or the air contains, a synthetic, fire-resistant lubricant.

5. IF A POLYCARBONATE BOWL is not usable for any reason, do not install it. Instead, reorder a new polycarbonate bowl and metal bowl guard.
6. CAUTION: certain compressor oils, household cleaners, solvents, paints, and fumes will attack polycarbonate bowls and can cause bowl failures. (Refer to list on page 5.)
7. DO INSPECT polycarbonate bowls daily to detect crazing, cracking, damage, or deterioration. Immediately replace any crazed, cracked, damaged or deteriorated bowl with a new polycarbonate bowl and metal bowl guard.



Polycarbonate bowl units are sold only with metal bowl guards. To minimize the danger of flying fragments in the event of polycarbonate bowl failure, the metal bowl guards should not be removed. If the unit is in service without the metal bowl guard installed, warranties are void, and Enerpac assumes no responsibility for any resulting loss.



IF A UNIT has been in service and does not have a metal bowl guard, order one and install before placing back in service.



DO NOT PLACE polycarbonate bowl units in service without metal bowl guard installed.



We cannot possibly list all harmful substances, so check with Enerpac for further information on polycarbonate plastic if you are unsure.

PARTIAL LIST OF MATERIALS THAT WILL ATTACK POLYCARBONATE BOWLS

Acetaldehyde	Carbon Disulfide	Ethylene Chlorohydrin	Perchloroethylene
Acetic Acid (conc.)	Carbon Tetrachloride	Ethylene Dichloride	Phenol
Acetone	Caustic Potash Solution	Ethylene Glycol	Phosphorous Hydroxyl Chloride
Acrylonitrile	Caustic Soda Solution	Formic Acid (conc.)	Phosphorous Trichloride
Ammonia	Chlorobenzene	Freon (refrigerant & propellant)	Propionoc Acid
Ammonium Flouride	Chloroform	Gasoline	Pyridine
Ammorium Hydroxide	Cresol	Hydrazine	Sodium Hydroxide
Ammonium Sulfide	Cyclohexanol	Hydrochloric Acid (conc.)	Sodium Sulfide
Antifreeze	Cyclohexanone	Lacquer Thinner	Styrene
Benzene	Cyclohexene	Methyl Alcohol	Sulfuric Acid (conc.)
Benzoic Acid	Dimethyl Formamide	Methylene Chloride	Sulphural Chloride
Benzyl Alcohol	Dioxane	Methylene Salicylate	Tetrahydronaphthalene
Brake Fluids	Ethane Tetrachloride	Milk of Lime (CaOH)	Thiopenne
Bromobenzene	Ethyl Acetate	Nitric Acid (conc.)	Toluene
Butyric Acid	Ethyl Ether	Nitobenzene	Turpentine
Carbolic Acid	Ethylamine	Nitrocellulos Lacquer	Xylene, and others

TRADE NAMES OF SOME COMPRESSOR OILS, RUBBER COMPOUNDS, AND OTHER MATERIALS THAT WILL ATTACK POLYCARBONATE BOWLS

Atlas "Perma-Guard"	Parco #1306 Neoprene
Buna N	Petron PD287
Cellulube #150 and #200	Prestone
Crylex #5 Cement	Pydraul AC
Eastman 910	Sears Regular Motor Oil
Garlock #98403 (polyurathane)	Sinclair Oil "Lily White"
Haskel #568-023	Some Loctite Compounds
Hilgard Co.'s Hil-phene	Stauffer Chemical FYRQUEL 3#150
Houghten & Co. oil #1120, #1130, #1055	Stillman #SR 269-75 (polyurathane)
Houtosafe 1000	Stillman #SR 513-70 (neoprene)
Kano Kroil	Tannergas
Keystone Penetrating Oil #2	Telar
Marvel Mystery Oil	Tenneco Anderol #495 \$ #500 Oils
Minn. Rubber 366Y	Titon
National Compound #N11	Zerex
"Nylock" VC-3	

Enerpac Worldwide Locations

Australia

ENERPAC, Applied Power
Australia Ltd.
Block V Unit 3
Regents Park Estate
391 Park Road
Regents Park NSW 2143
(P.O. Box 261) Australia
Tel: +61 297 438 988
Fax: +61 297 438 648

Brazil

Power Packer do Brasil Ltda.
Rua dos Inocentes, 587
04764-050 - Sao Paulo (SP)
Tel: +55 11 5687 2211
Fax: +55 11 5686 5583
Toll Free in Brazil:
Tel: 000 817 200 6718
vendasbrasil@enerpac.com

Canada

Actuant Canada Corporation
6615 Ordan Drive, Unit 14-15
Mississauga, Ontario L5T 1X2
Tel: +1 905 564 5749
Fax: +1 905 564 0305

Toll Free:

Tel: +1 800 268 4987
Fax: +1 800 461 2456

Technical Inquiries:

techservices@enerpac.com

China

Actuant China Ltd.
1F, 269 Fute N. Road
Waigaoqiao Free Trade Zone
Pudong New District
Shanghai, 200 131 China
Tel: +86 21 5866 9099
Fax: +86 21 5866 7156

Actuant China Ltd. (Beijing)
709A Xin No. 2
Diyang Building
Dong San Huan North Rd.
Beijing City, 100028 China
Tel: +86 10 845 36166
Fax: +86 10 845 36220

◆ e-mail: info@enerpac.com

Greece, Central and Eastern Europe

ENERPAC B.V.
Storkstraat 25
P.O. Box 269, 3900 AG
Veenendaal
The Netherlands
Tel: +31 318 535 9936
Fax: +31 318 535 951

France, Africa

ACTUANT FRANCE S.A.
B.P. 200
Parc d'Activités
du Moulin de Massy
F-91882 Massy CEDEX
(Paris) France
Tel: +33 1 601 368 68
Fax: +33 1 692 037 50

Germany, Austria

ENERPAC, Applied Power GmbH
P.O. Box 300113
D-40401 Düsseldorf
Germany
Tel: +49 211 471 490
Fax: +49 211 471 49 28

India

ENERPAC Hydraulics
(India) Pvt. Ltd.
Plot No. A/571
MIDC, TTC Industrial Area
Mahape-400 701
Navi Mumbai, India
Tel: +91 22 778 1779
Fax: +91 22 778 1473

Italy

ENERPAC
Applied Power Italiana S.p.A.
Via Canova 4
20094 Corsico (Milano)
Tel: +39 02 4861 111
Fax: +39 02 4860 1288

Japan

Applied Power Japan Ltd.
1-1-11, Shimomae
Toda-shi
Saitama Pref.
Japan 335-0016
Tel: +81 48 430 2311
Fax: +81 48 430 1117

Mexico

Grupo Industrial Baja Tec, S. A. De C. V.
ATN.
Apdo. Postal # 1 - 147
Admon. # 1, Pachuca, Hidalgo
CP. 42001
Mexico

The Netherlands, Belgium, Luxembourg, Sweden, Denmark, Norway, Finland

ENERPAC B.V.
Storkstraat 25
P.O. Box 269, 3900 AG Veenendaal
The Netherlands
Tel: +31 318 535 911
Fax: +31 318 525 613
+31 318 535 848

Russia and CIS (excl. Caspian Sea Countries)

ENERPAC
Leninsky Prospect 95A
117313, Moscow, Russia.
Tel/Fax: +7(095) 936-2005
Tel/Fax: +7(095) 198-3094
Tel/Fax: +7(095) 938-4655
Mobil: +7(903) 731-9558

Singapore

Actuant Asia Pte. Ltd.
25 Serangoon North Ave. 5
#03-01 Keppel Digihub
Singapore 554914
Thomson Road
P.O. Box 114
Singapore 915704
Tel: +65 64 84 5108
+65 64 84 3737
Fax: +65 64 84 5669

South Korea

ENERPAC
Applied Power Korea Ltd.
163-12 Dodang-Dong
Wonmi-Ku, Buchun-shi
Kyunggi-Do
Republic of Korea
Tel: +82 32 675 08 36
Fax: +82 32 675 30 02/73

◆ internet: www.enerpac.com

Spain, Portugal

ENERPAC
C/San José Artesano 8
Pol. Ind.
28108 Alcobendas
(Madrid) Spain
Tel: +34 91 661 11 25
Fax: +34 91 661 47 89

Middle East, Turkey and Caspian Sea

ENERPAC Middle East FZE
P.O. Box 18004
Jebel Ali, Dubai
United Arab Emirates
Tel: +971 (0)4 8872686
Fax: +971 (0)4 8872687

United Kingdom, Ireland

ENERPAC Ltd., P.O. Box 33
New Romney, TN28 8QF
United Kingdom
Tel: +44 01527 598 900
Fax: +44 01527 585 900

USA, Latin America and Caribbean

ENERPAC
P.O. Box 3241
6100 N. Baker Road
Milwaukee, WI 53209 USA
Tel: +1 262 781 6600
Fax: +1 262 783 9562

User inquiries:

+1 800 433 2766

Distributor inquiries/orders:

+1 800 558 0530

Technical Inquiries:

techservices@enerpac.com

All Enerpac products are guaranteed against defects in workmanship and materials for as long as you own them.
For your nearest authorized Enerpac Service Center, visit us at www.enerpac.com