

# Swing cylinders

## Swing Cylinders

Enerpac's complete line of swing cylinders provide maximum clamping force in the smallest possible package. With several mounting and operation styles available, Enerpac can fit any clamping need you can think of. Our unique patented clamp arm design is an industry exclusive, and makes Enerpac's swing cylinder line more versatile than ever before. Made to the highest quality standards, Enerpac swing cylinders will provide maximum performance and trouble free operation.

## Work Supports

Enerpac's line of work support cylinders gives you maximum holding force in a compact package. Incorporating innovative material combinations, our work supports feature the lowest lock-up pressures in the industry. Also, the use of corrosion resistant materials enables Enerpac work supports to stand up time and time again to even the most abrasive applications.













## Technical support

Refer to the "Yellow Pages" of this catalog for:

- Safety instructions
- Basic hydraulic information
- Advanced hydraulic technology
- FMS (Flexible Machining Systems) technology
- Conversion charts and hydraulic symbols

 113

# & Work supports

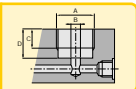
	▼ series	▼ page	
Clamp arm and swing cylinders size selection	CA, MA, SC, SU, SL, ST, MP	10 - 11	
Swing cylinder range overview		12 - 13	
Upper flange swing cylinders	SU	14 - 15	
Lower flange swing cylinders	SL	16 - 17	
Threaded body swing cylinders	ST	18 - 19	
Cartridge model swing cylinders	SC	20 - 21	
<i>Collet-Lok</i> <sup>®</sup> swing cylinders	MP	22 - 23	
Clamp arms	CA, MA CAC	24 - 26	
Swing clamps	ASC	27	
Work support range overview		28 - 29	
Hydraulic advance work supports	WF	30 - 31	
Spring advance work supports	WS	32 - 33	
<i>Collet-Lok</i> <sup>®</sup> work supports	MP	34 - 35	
Work support mounting dimensions	WF, WS	36 - 37	

# Selecting the swing cylinder for your applications

Clamp arms transmit the force generated by swing cylinders



▶ The clamp arms transmit the force generated by the swing cylinder to the workpiece. Clamp arms are available in a variety of lengths. After you have determined the required clamp arm length and the clamping force you can select the swing cylinder type and mounting method.

The maximum clamp arm length of a given size of swing clamp is limited. This limitation is due to the bending moment on the plunger. The bending moment applied to the plunger is a function of the real clamping force and length of the clamp arm. Never exceed the maximum pressure or flow for any given clamp arm length. Excessive weight will limit flow.

The unique Enerpac swing clamp and patented clamp arm guarantee the lowest frictional losses and most efficient clamp design available on the market today.

■ Hydraulic fixture with swing cylinders on two faces for more efficient production.



## **i** Determine the right size of your swing cylinder

### Clamp arm length and clamping force

The maximum operating pressure, clamping force and length of clamp arm will determine your size of swing clamp. The real operating pressure is a function of both the arm length and clamping force.

In the chart below you select the required clamp arm length and clamping force. The use of different length clamp arms requires reduction in applied pressure and resulting clamp force. The diagrams on the next page show this relation.

### Pivoting T-arms

#### Oil flow versus arm length

The distribution of the clamp arm force is based upon the length of the T-arm as measured from the pivoting point.

### **!** Important

When using the standard and long clamp arms from the CAS and CAL series consult the diagrams shown on the next page.

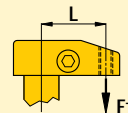

11▶

When using T-arms use the formula below.

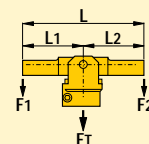

$$L = L_1 + L_2 \quad F_1 = F_T \times \frac{L_2}{L_1 + L_2}$$

$$F_T = F_1 + F_2 \quad F_2 = F_T \times \frac{L_1}{L_1 + L_2}$$

For diagrams of allowable oil flow vs T-arm length see:

26▶

## **globe** Product selection

Clamp arm length L mm min. - max.	Clamping force F <sub>T</sub> kN max. - min	For Swing Cylinder Model	With Clamp Arm Model number
--	--	--------------------------	-----------------------------

#### ▼ Swing Cylinders SU, SL, ST and SC series

25 - 78	2,2 - 0,5	22	CAS, CAL-22
40 - 130	5,6 - 1,0	52	CAS, CAL-52
45 - 155	9,0 - 2,2	92	CAS, CAL-92
51 - 157	11,6 - 2,0	121, 122	CAS-121, CAL-122
55 - 173	18,7 - 4,0	202	CAS, CAL-202
68 - 175	33,8 - 9,0	352	CAS, CAL-352

#### ▼ Collet-Lok® Swing Cylinders MP series

40 - 100	4,1 - 1,1	50	MA-540
50 - 125	8,9 - 2,5	100	MA-1050
70 - 160	37,8 - 9,5	300	MA-3070

#### ▼ Pivoting T-arms for SU, SL, ST and SC series swing cylinders

152 <sup>1)</sup>	2 x 2,8	52	CAC, CAPT-52
203 <sup>1)</sup>	2 x 4,5	92	CAC, CAPT-92
203 <sup>1)</sup>	2 x 5,8	122	CAC, CAPT-122
203 <sup>1)</sup>	2 x 9,3	202	CAC, CAPT-202
228 <sup>1)</sup>	2 x 16,9	352	CAC, CAPT-352

<sup>1)</sup> Lmax. for T-arms.

# Selection Swing Cylinders & Clamp Arms

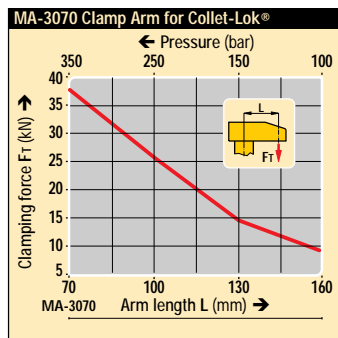
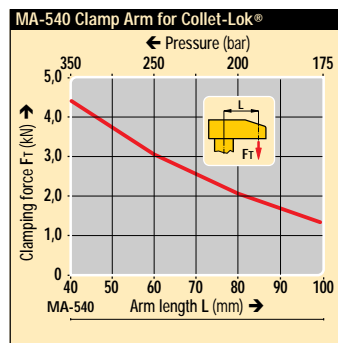
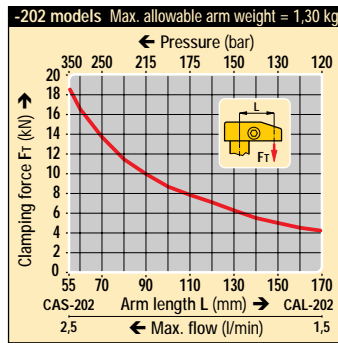
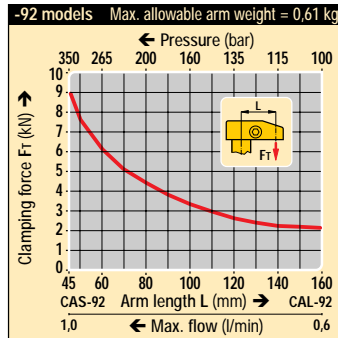
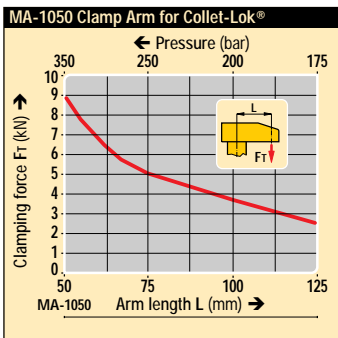
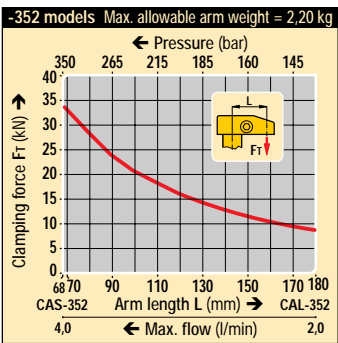
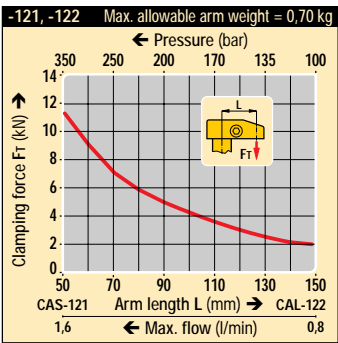
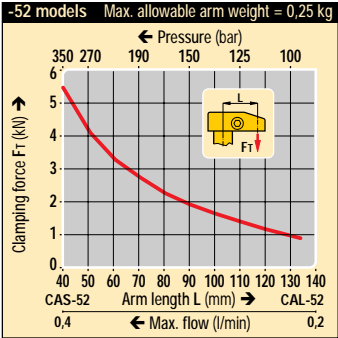
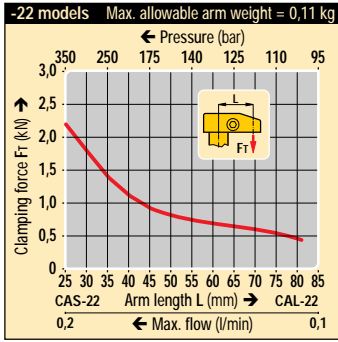

Arm length: 25 - 175 mm

Clamp force: 0,5 - 37,8 kN

- E** Cilindros giratorios
- F** Vérins de bridage pivotants
- D** Schwenkspannzylinder

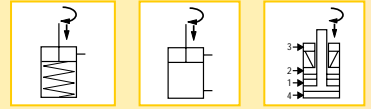

## Important

Do not exceed maximum oil flow. If flow rates are exceeded, swing cylinder indexing mechanism may be permanently damaged.

Do not exceed maximum operating pressure. If operating pressures are exceeded swing cylinder and other components may be permanently damaged.

## Options

Swing cylinders

12



Collet-Lok® swing cylinders

22



Clamp arms

24



For actual clamping force at reduced pressures, we invite you to download our "Swing Clamp Selection Tool" through the Internet at [www.enerpac.com](http://www.enerpac.com).

# Swing cylinders *Application & selection*

Shown: SCRD-122, SULD-22, MPFL-50

Swing cylinders  
Work supports



► Enerpac swing cylinders allow unobstructed part fixturing and placement. The plunger rod and the attached clamp arm, rotate 90 degrees in either a clockwise or counter clockwise direction, then travel down an additional distance to clamp against the fixtured part. Upon release of clamping pressure, the clamp arm rotates back 90 degrees in the opposite direction to allow for part removal and new part placement.

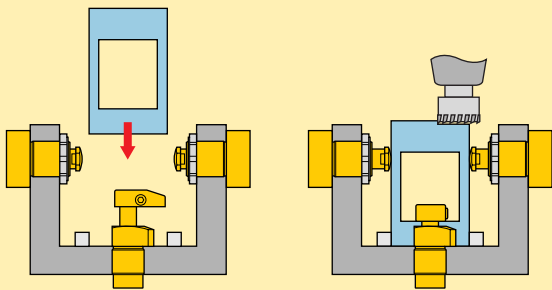

■ *Swing cylinders used in conjunction with work supports and other Enerpac components to positively hold the workpieces during machining operations.*



## Compact and full featured design

- Compact design allows for efficient fixture layout
- Variety of mounting styles to meet design needs
- Double and single-acting cylinders to suit a variety of hydraulic requirements
- Choice of porting styles to meet system and design requirements
- All cylinders are available as left and right turning models
- Large ball and cam design on 22, 52 and 121 models, allows swing rotation to be changed easily
- Kick-out mechanism on 92, 202, and 352 models prevents damage to cylinder from high flow rates or misapplication

## **i** Select your swing cylinder type:

### Single-acting

- The obvious choice when there are few system restrictions, and there are not many units retracting simultaneously
- Fewer valving requirements which results in a less complex circuit
- Innovative clamp arm design allows quick and secure arm positioning

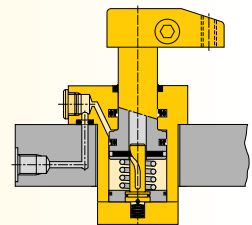

### Double-acting

- Used when greater control is required during the unclamp cycle
- When timing sequences are critical: less sensitive to system back pressures, resulting from long tube lengths or numerous components being retracted at the same time
- Innovative clamp arm design allows quick and secure arm positioning

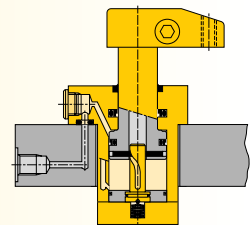

### Collet-Lok® Positive locking

- Enerpac Collet-Lok® positive locking cylinders are designed to mechanically hold the workpiece while hydraulic pressure is removed. After machining, hydraulic pressure is applied to unclamp the workpiece
- Used when live hydraulics are not available during the clamp cycle or when parts must be held for long periods of time
- This design is an industry exclusive

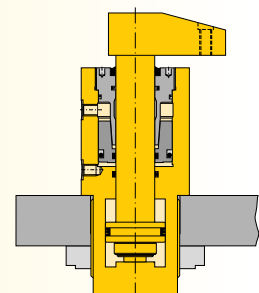

For Collet-Lok® Positive locking swing cylinders, see □22 ▶



## Select your mounting method:

### SU series, Upper flange mounting

- Flexible design allows for manifold or threaded oil port connection
- Fixture hole does not require tight tolerances
- Easy installation with only 3 or 4 mounting bolts

14 ▶

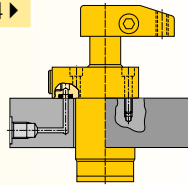

### SL series, Lower flange mounting

- Flexible design allows for manifold or threaded port connection
- No fixture hole required
- Easy installation with only 3 or 4 mounting bolts

16 ▶

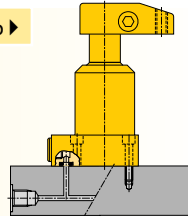

### ST series, Threaded body mounting

- Body thread for precise cylinder height positioning
- Threaded oil port connection
- Can be threaded directly into the fixture and secured in position by means of standard flange nuts

18 ▶

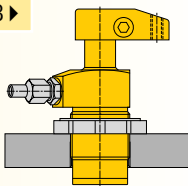



### SC series, Cartridge mounting

- Minimal space required on fixture
- External plumbing not required
- Allows close positioning of adjoining units
- Cylinder can be completely recessed in fixture

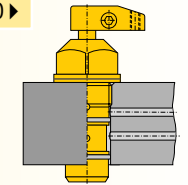
20 ▶

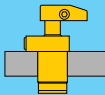

## Product selection

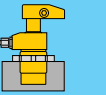
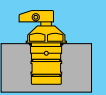
Clamping force <sup>1)</sup>	Stroke		Upper flange	Lower flange	Threaded body	Cartridge
	mm	mm				
kN	clamping	total				
<b>▼ Single-acting</b>						
Model number <sup>2)</sup>						
2,1	8,1	16,5	SURS-22	SLRS-22	STRS-22	SCRS-22
4,9	9,9	22,6	SURS-52	SLRS-52	STRS-52	SCRS-52
8,0	11,9	22,1	SURS-92	SLRS-92	STRS-92	-
10,7	12,7	28,4	SURS-121	SLRS-121	STRS-121	SCRS-122
17,4	14,0	27,9	SURS-202	SLRS-202	STRS-202	-
33,1	16,0	30,0	SURS-352	SLRS-352	STRS-352	-
<b>▼ Double-acting</b>						
Model number <sup>2)</sup>						
2,2	8,1	16,5	SURD-22	SLRD-22	STRD-22	SCRD-22
5,6	9,9	22,6	SURD-52	SLRD-52	STRD-52	SCRD-52
9,0	11,9	22,1	SURD-92	SLRD-92	STRD-92	-
9,0	32,0	41,9	SURDL-92	-	-	-
11,6	12,7	28,4	SURD-121	SLRD-121	STRD-121	SCRD-122
11,6	31,8	47,5	SURDL-121	-	-	-
18,7	14,0	27,9	SURD-202	SLRD-202	STRD-202	-
33,8	16,0	30,0	SURD-352	SLRD-352	STRD-352	-
33,8	31,8	46,5	SURDL-352	-	-	-
<b>▼ Collet-Lok® Positive locking</b>						
Model number <sup>2)</sup>						
4,4	8,1	23,9	-	MPFR-50	-	-
8,9	11,9	27,9	-	MPFR-100	MPTR-100	-
37,8	9,9	41,9	-	MPFR-300	MPTR-300	-

<sup>1)</sup> With standard clamp arm. Clamp arms are sold separately (10, 24). Clamping forces for single-acting models are reduced in order to overcome return spring force.

<sup>2)</sup> For left turning swing cylinders replace the R in the model number for an L.

Force: 2,1 - 37,8 kN

Stroke: 16,5 - 47,5 mm

Pressure: 35 - 350 bar

- E** Cilindros giratorios
- F** Vérins de bridage pivotants
- D** Schwenkspannzylinder

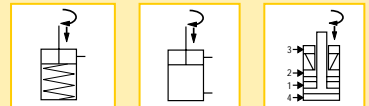

## Options

Available as both left and right turning

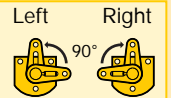

Clamp arms

24 ▶



Work supports

28 ▶



Sequence Valves

92 ▶



## Important

Actual clamping may only take place when the cylinder has completed it's 90° swing.

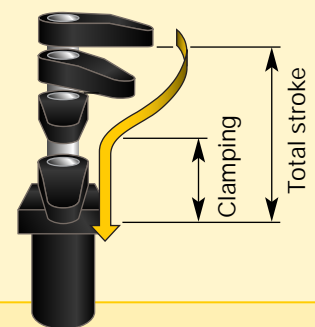

Other swing angles available upon request. Contact Enerpac for info.

# Swing cylinders - Upper flange models

Shown: SURS-202, SURS-52



Swing cylinders  
Work supports

## ► SU series

The Enerpac upper flange swing cylinders are designed for integrated manifold mounting solutions. Hydraulic connections are made through SAE or BSPP oil connection or the standard integrated O-ring ports.

BSPP oil connection

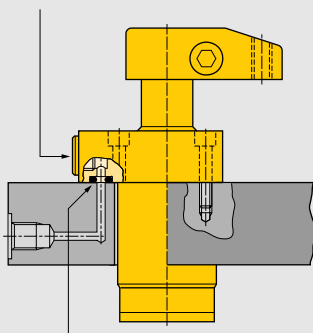

Integrated O-ring port

■ Enerpac upper flange swing clamps integrated into a fully automated machining system.





## Minimal mounting height

...when space is at a premium

- Flexible design allows for manifold or threaded port connection
- Low profile mounting style allows body to be below mounting surface
- Simple mounting preparation and easy installation – 3 or 4 mounting bolts
- Easy to machine fixture hole – does not require tight tolerances
- Double oil connection – threaded port or manifold mount
- Symmetrical rectangular flange design enables clamping at three sides of the cylinder

## 🌐 Product selection

Clamping force <sup>1)</sup>	Stroke		Left turning 90° 	Right turning 90° 	Cylinder effective area		Oil capacity		Max. oil flow <sup>1)</sup>	Standard clamp arm Sold separately □ 24 ▶
	kN	Clamp.			Total	cm <sup>2</sup>	cm <sup>3</sup>	Clamp		
▼ Single-acting Model number <sup>2)</sup>										
2,1	8,1	16,5	SULS-22	SURS-22	0,77	–	1,31	–	0,2	CAS-22
4,9	9,9	22,6	SULS-52	SURS-52	1,81	–	4,10	–	0,4	CAS-52
8,0	11,9	22,1	SULS-92	SURS-92	3,16	–	6,88	–	1,0	CAS-92
10,7	12,7	28,4	SULS-121	SURS-121	4,06	–	11,47	–	1,6	CAS-121
17,4	14,0	27,9	SULS-202	SURS-202	7,10	–	19,99	–	2,3	CAS-202
33,1	16,0	30,0	SULS-352	SURS-352	12,39	–	37,20	–	3,9	CAS-352
▼ Double-acting Model number <sup>2)</sup>										
2,2	8,1	16,5	SULD-22	SURD-22	0,77	1,55	1,31	2,62	0,2	CAS-22
5,6	9,9	22,6	SULD-52	SURD-52	1,81	3,81	4,10	8,69	0,4	CAS-52
9,0	11,9	22,1	SULD-92	SURD-92	3,16	8,06	6,88	17,70	1,0	CAS-92
9,0	32,0	41,9	SULD-92	SURDL-92	3,16	8,06	13,27	30,48	1,0	CAS-92
11,6	12,7	28,4	SULD-121	SURD-121	4,06	7,94	11,47	22,94	1,6	CAS-121
11,6	31,8	47,5	SULD-121	SURDL-121	4,06	7,94	15,90	37,69	1,6	CAS-121
18,7	14,0	27,9	SULD-202	SURD-202	7,10	15,16	19,99	42,61	2,3	CAS-202
33,8	16,0	30,0	SULD-352	SURD-352	12,39	23,74	37,20	71,28	3,9	CAS-352
33,8	31,8	46,5	SULD-352	SURDL-352	12,39	23,74	57,85	110,94	3,9	CAS-352

<sup>1)</sup> With standard clamp arm. Clamp arms are sold separately (□ 10, 24). Clamping forces for single-acting models are reduced in order to overcome return spring force.

Note: Call Enerpac to order models with SAE port connections.

<sup>2)</sup> For models with straight plunger movement, replace L or R with S.

## 📏 Dimensions in mm [D]

Left turning models	A	B	C	D	D1	D2	F	H	K	M	N	P
				ø			ø					
▼ Single-acting												
SULS-22	112,0	59	42,5	27,9	47,2	45	10	11	16	–	15,5	24
SULS-52	134,9	69	49,6	34,8	54,1	57	16	10	19	–	19,1	40
SULS-92	143,0	75	50,1	47,8	70,1	54	25	13	25	15,5	26,9	45
SULS-121	171,5	86	55,4	47,8	66,8	73	22	10	30	–	25,4	51
SULS-202	165,1	86	55,9	63,0	85,1	70	32	13	30	23,6	35,1	55
SULS-352	186,4	98	58,0	77,0	100,1	89	38	13	40	27,9	44,5	68
▼ Double-acting												
SULD-22	112,0	59	42,5	27,9	47,2	45	10	11	16	–	15,5	24
SULD-52	134,9	69	49,6	34,8	54,1	57	16	10	19	–	19,1	40
SULD-92	143,0	75	50,1	47,8	70,1	54	25	13	25	–	26,9	45
SULD-92	182,9	95	69,9	47,8	70,1	54	25	13	25	–	26,9	45
SULD-121	171,5	86	55,4	47,8	66,8	73	22	10	30	–	25,4	51
SULD-121	228,6	105	74,5	47,8	66,5	73	22	10	30	–	25,4	51
SULD-202	165,1	86	55,9	63,0	85,1	70	32	13	30	–	35,1	55
SULD-352	186,4	98	58,0	77,0	100,1	89	38	13	40	–	44,5	68
SULD-352	217,9	114	74,5	77,0	100,1	89	38	13	40	–	44,5	68

Note: Dimensions shown with standard clamp arm.



**A** Installation dimensions in mm

Clamping force <sup>1)</sup> kN	Fixture hole Ø D3 ±0,3	Mounting thread J	Min. depth J2	Manifold O-ring <sup>2)</sup> ARP nr. or Inside Ø x thickness
2,2	29,0	M5	16,5	568-010
5,6	35,5	M6	16,5	568-011
9,0	49,0	M6	15,0	4,32 x 3,53
11,6	49,0	.312-24 UN	20,3	568-011
18,7	63,5	M8	17,0	4,32 x 3,53
33,8	78,0	M10	18,8	4,32 x 3,53

<sup>1)</sup> With standard clamp arm.  
<sup>2)</sup> Polyurethane, 92 Durometer

Note: Mounting bolts and O-rings included.

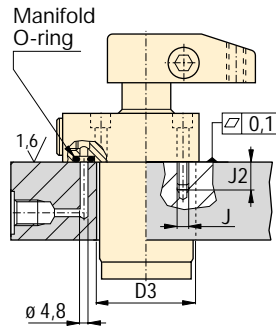

-22, 52, 121

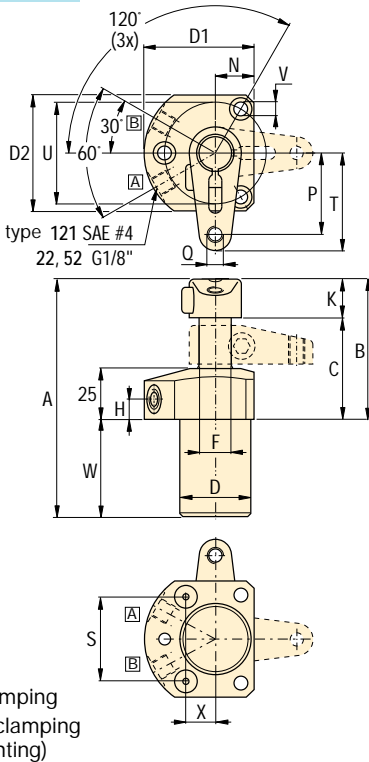

-92, 202, 352

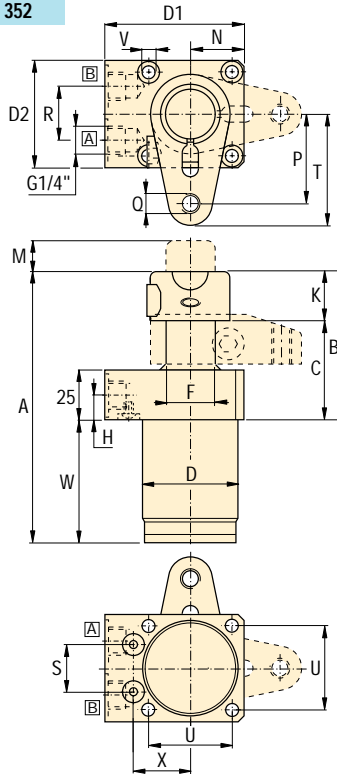

[A] = Clamping  
[B] = Unclamping (venting)

Force:	2,1 - 33,8 kN
Stroke:	16,5 - 47,5 mm
Pressure:	35 - 350 bar

- E** Cilindros giratorios
- F** Vérins de bridage pivotants
- D** Schwenkspannzylinder

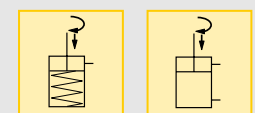

**Options**

- Clamp arms ▣24
- Work supports ▣28
- Collet-Lok® swing cylinders ▣22
- Sequence Valves ▣92

**! Important**  
Single-acting cylinders can be vented through the manifold port.

The upper flange swing cylinder has a bolt pattern which is identical to its lower flange equivalent, enabling interchangeability.

In case there is a risk of machining coolants and debris being inhaled via the breather vent, it is recommended to pipe this port to an area outside the fixture that is protected from machining coolants and debris.

Do not exceed maximum flow rates.

	Q	R	S	T	U	V	W	X	kg	Right turning models
						Ø				
										Single-acting ▼
	M6x1	-	21,0	30	40	5,7	53,1	18,1	0,5	SURS-22
	M8x1,25	-	41,0	48	50	6,8	66,0	14,3	1,1	SURS-52
	M10x1,5	26	23,6	56	42	6,9	68,1	28,7	2,0	SURS-92
	.375-16UN	-	52,4	61	64	8,8	85,9	18,4	1,6	SURS-121
	M12x1,75	26	29,2	71	55	8,5	79,0	35,6	3,5	SURS-202
	M16x2	25	34,4	84	70	10,8	88,4	41,6	5,5	SURS-352
										Double-acting ▼
	M6x1	-	21,0	30	40	5,7	53,1	18,1	0,5	SURD-22
	M8x1,25	-	41,0	48	50	6,8	66,0	14,3	1,1	SURD-52
	M10x1,5	26	23,6	56	42	6,9	68,1	28,7	2,0	SURD-92
	M10x1,5	26	23,6	56	42	6,9	87,9	28,7	2,6	SURDL-92
	.375-16UN	-	52,4	61	64	8,8	85,9	18,4	1,6	SURD-121
	.375-16UN	-	52,4	61	64	8,8	124,0	18,4	1,8	SURDL-121
	M12x1,75	26	29,2	71	55	8,5	79,0	35,6	3,5	SURD-202
	M16x2	25	34,4	84	70	10,8	88,4	41,6	5,5	SURD-352
	M16x2	25	34,4	84	70	10,8	104,3	41,6	6,8	SURDL-352

Note: U = Bolt circle, U1 = Manifold port circle.

Swing cylinders  
 Work supports  
 Linear cylinders  
 Power sources  
 Valves  
 System components  
 Yellow pages

# Swing cylinders - Lower flange models

Shown: SLRD-52, SLRS-202



Swing cylinders  
Work supports

## ▶ SL series

Enerpac lower flange series swing cylinders can be bolted to the fixture, allowing easy installation of the unit and does not require machined fixture holes. Hydraulic connections are made through SAE or BSPP oil connection or the standard integrated O-ring ports.

BSPP oil connection

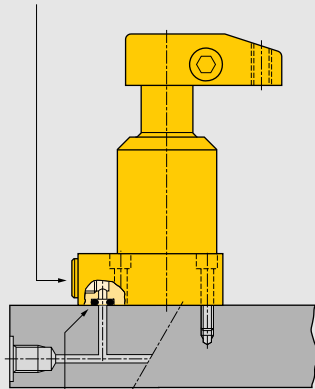

Integrated O-ring port

■ Lower flange swing cylinders mounted to the face of the fixture.





## No fixture hole required

...cylinder can be bolted directly to fixture

- Flexible design allows for manifold or threaded port connection
- No fixture hole preparation required
- Easiest mounting preparation in the swing cylinder line
- Symmetrical rectangular flange design enables clamping at three sides of the cylinder
- Allows extra large parts to be clamped

## Product selection

Clamping force <sup>1)</sup>	Stroke		Left turning 	Right turning 	Cylinder effective area		Oil capacity		Max. oil flow <sup>1)</sup>	Standard clamp arm Sold separately □ 24 ▶
	kN	mm			cm <sup>2</sup>	cm <sup>3</sup>	l/min			
▼ Single-acting										
Model number <sup>2)</sup>										
2,1	8	16,5	SLLS-22	SLRS-22	0,77	-	1,31	-	0,2	CAS-22
4,9	10	22,6	SLLS-52	SLRS-52	1,81	-	4,10	-	0,4	CAS-52
8,0	12	22,1	SLLS-92	SLRS-92	3,16	-	6,88	-	1,0	CAS-92
10,7	13	28,4	SLLS-121	SLRS-121	4,06	-	11,47	-	1,6	CAS-121
17,4	14	27,9	SLLS-202	SLRS-202	7,10	-	19,99	-	2,3	CAS-202
33,1	16	30,0	SLLS-352	SLRS-352	12,39	-	37,20	-	3,9	CAS-352
▼ Double-acting										
Model number <sup>2)</sup>										
2,2	8	16,5	SLLD-22	SLRD-22	0,77	1,55	1,31	2,62	0,2	CAS-22
5,6	10	22,6	SLLD-52	SLRD-52	1,81	3,81	4,10	8,69	0,4	CAS-52
9,0	12	22,1	SLLD-92	SLRD-92	3,26	8,06	6,88	17,70	1,0	CAS-92
11,6	13	28,4	SLLD-121	SLRD-121	4,06	7,94	11,47	22,94	1,6	CAS-121
18,7	14	27,9	SLLD-202	SLRD-202	7,10	15,26	19,99	42,61	2,3	CAS-202
33,8	16	30,0	SLLD-352	SLRD-352	12,39	23,74	37,20	71,38	3,9	CAS-352

<sup>1)</sup> With standard clamp arm. Clamp arms are sold separately (□ 10, 24). Clamping forces for single-acting models are reduced in order to overcome return spring force.

<sup>2)</sup> For models with straight plunger movement, replace L or R with S.

Note: Call Enerpac to order models with SAE port connections.

## Dimensions in mm [⊥⊕]

Left turning models	A	C	D	D1	D2	F	H	K	M	N	P
			∅			∅					
▼ Single-acting											
SLLS-22	112	96,5	27,9	47,2	45	10	14	16	-	15,5	24
SLLS-52	134,9	115,6	34,8	54,1	57	16	14	19	-	19,1	40
SLLS-92	151	126,1	47,8	70,1	54	25	12	25	15,5	26,9	45
SLLS-121	171	141,4	47,8	66,8	73	22	16	30	-	25,4	51
SLLS-202	173	142,9	63,8	85,1	70	32	12	30	23,6	35,1	55
SLLS-352	195	151,0	80,0	100,1	89	38	12	40	27,9	44,5	68
▼ Double-acting											
SLLD-22	112	96,5	27,9	47,2	45	10	14	16	-	15,5	24
SLLD-52	134,9	115,6	34,8	54,1	57	16	14	19	-	19,1	40
SLLD-92	151	126,1	47,8	70,1	54	25	12	25	-	26,9	45
SLLD-121	171	126,0	47,8	66,8	73	22	16	30	-	25,4	51
SLLD-202	173	142,9	63,8	85,1	70	32	12	30	-	35,1	55
SLLD-352	195	151,0	80,0	100,1	89	38	12	40	-	44,5	68

Note: Dimensions shown with standard clamp arm.



**A** Installation dimensions in mm

Clamping force <sup>1)</sup> kN	Mounting thread J	Minimum thread depth J2	Manifold O-ring <sup>2)</sup> ARP nr. or Inside Ø x thickness
2,2	M5	16,5	568-010
5,6	M6	16,5	568-011
9,0	M6	15,0	4,32 x 3,53
11,6	.312-24 UNF	20,3	568-011
18,7	M8	17,0	4,32 x 3,53
33,8	M10	18,8	4,32 x 3,53

<sup>1)</sup> With standard clamp arm.  
<sup>2)</sup> Polyurethane, 92 Durometer

Note: Mounting bolts and O-rings included.

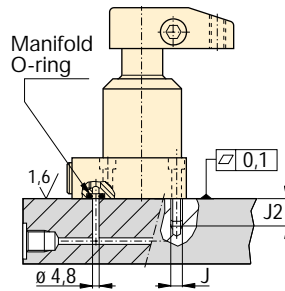

-22, 52, 121

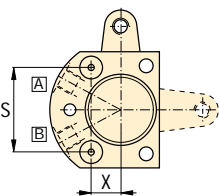
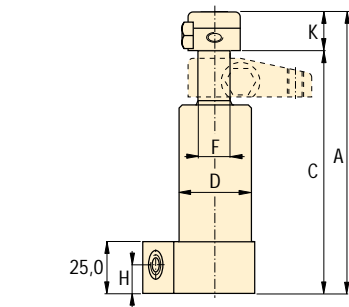
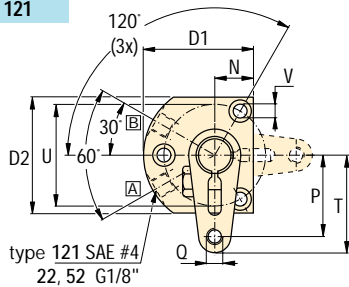

**A** = Clamping  
**B** = Unclamping (venting)

-92, 202, 352

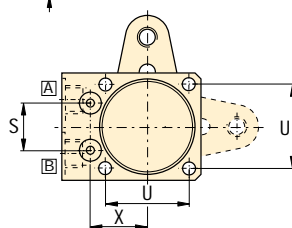
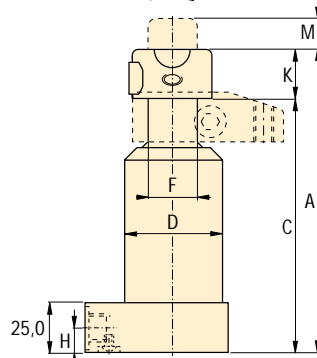
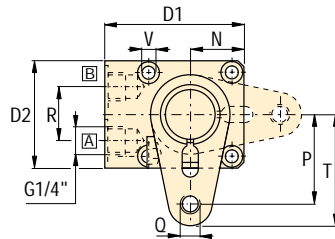

Force: 2,1 - 33,8 kN

Stroke: 16,5 - 30,0 mm

Pressure: 34 - 350 bar

- E** Cilindros giratorios
- F** Vérins de bridage pivotants
- D** Schwenkspannzylinder

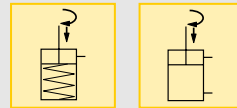

**B** Options

Clamp arms  **24**

Work supports  **28**

Collet-Lok® swing cylinders  **22**

Sequence Valves  **92**

**!** Important

Single-acting cylinders can be vented through the manifold port.

The lower flange swing cylinder has a bolt pattern which is identical to its upper flange equivalent, enabling interchangeability.

In case there is a risk of machining coolants and debris being inhaled via the breather vent, it is recommended to pipe this port to an area outside the fixture that is protected from machining coolants and debris.

Do not exceed maximum flow rates.

	Q	R	S	T	U	V	X	Weight kg	Right turning models
						ø			
	M6x1	-	21,0	31	40	5,6	18,1	0,5	SLRS-22
	M8x1,25	-	41,0	48	50	6,9	14,3	1,1	SLRS-52
	M10x1,5	26	23,6	56	42	6,9	28,7	2,0	SLRS-92
	.375-16UN	-	52,4	62	64	8,9	18,4	1,6	SLRS-121
	M12x1,75	26	29,0	70	55	8,4	35,1	3,5	SLRS-202
	M16x2	25	34,4	83	70	10,7	41,6	5,5	SLRS-352
	M8x1,25	-	21,0	31	40	5,6	18,1	0,5	SLRD-22
	.312-18UN	-	41,0	48	50	6,9	14,3	1,1	SLRD-52
	M10x1,5	-	23,6	56	42	6,9	28,7	2,0	SLRD-92
	.375-16UN	-	52,4	62	64	8,9	18,4	1,6	SLRD-121
	M12x1,75	26	29,0	70	55	8,4	35,1	3,5	SLRD-202
	M16x2	25	34,4	83	70	10,7	41,6	5,5	SLRD-352

Note: U = Bolt circle, U1 = Manifold port circle.

# Swing cylinders - Threaded body models

Shown: STRD-52, STRD-202



## ST series

Enerpac threaded body swing cylinders are threaded directly into the fixture.

The cylinder height is adjusted to the appropriate height, and then locked in place using a flange nut (□ 72).

BSPB oil connection

Flange nut

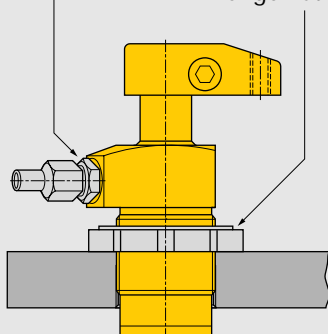

Threaded body swing cylinders allow the clamp to be buried in the fixture to minimize the required area, while the height remains adjustable.



## Cylinders can be threaded directly into fixture

...can be secured at any height

- Body thread for precise cylinder height positioning
- Threaded port connection
- Easy installation and removal
- Greatest flexibility in fixture design

## Product selection

Clamping force <sup>1)</sup>	Stroke		Left turning	Right turning	Cylinder effective area		Oil capacity		Max. oil flow <sup>1)</sup>	Standard clamp arm Sold separately □ 24 ▶
	kN	mm			cm <sup>2</sup>	cm <sup>3</sup>				
	Clamp.	Total			Clamp	Un-clamp	Clamp	Un-clamp	l/min	
▼ Single-acting			Model number <sup>2)</sup>							
2,1	8	16,5	STLS-22	STRS-22	0,77	-	1,31	-	0,2	CAS-22
4,9	10	22,6	STLS-52	STRS-52	1,81	-	4,10	-	0,4	CAS-52
8,0	12	22,1	STLS-92	STRS-92	3,16	-	6,88	-	1,0	CAS-92
10,7	13	28,4	STLS-121	STRS-121	4,06	-	11,47	-	1,6	CAS-121
17,4	14	27,9	STLS-202	STRS-202	7,10	-	19,99	-	2,3	CAS-202
33,1	16	30,0	STLS-352	STRS-352	12,39	-	37,20	-	3,9	CAS-352
▼ Double-acting			Model number <sup>2)</sup>							
2,2	8	16,5	STLD-22	STRD-22	0,77	1,55	1,31	2,46	0,2	CAS-22
5,6	10	22,6	STLD-52	STRD-52	1,81	3,81	4,10	8,52	0,4	CAS-52
9,0	12	22,1	STLD-92	STRD-92	3,16	8,06	6,88	17,70	1,0	CAS-92
11,6	13	28,4	STLD-121	STRD-121	4,06	7,94	11,47	22,94	1,6	CAS-121
18,7	14	27,9	STLD-202	STRD-202	7,10	15,16	19,99	42,61	2,3	CAS-202
33,8	16	30,0	STLD-352	STRD-352	12,39	23,74	37,20	71,28	3,9	CAS-352

<sup>1)</sup> With standard clamp arm. Clamp arms are sold separately (□ 10, 24). Clamping forces for single-acting models are reduced in order to overcome return spring force.

<sup>2)</sup> For models with straight plunger movement, replace L or R with S.

Note: Call Enerpac to order models with imperial thread and SAE port connections.

## Dimensions in mm [□ ⊕]

Left turning models	A	B	C	C1	D	D1	D2	F	G	H
					∅			∅		
▼ Single-acting										
STLS-22	112	59	42,5	25	M28 x 1,5	39,4	33	10	G1/8"	10
STLS-52	135	69	49,6	25	M35 x 1,5	47,5	38	16	G1/8"	10
STLS-92	143	80	55,1	30	M48 x 1,5	62,5	48	25	G1/4"	13
STLS-121	171	86	55,4	25	1.875-16 UNF	60,5	51	22	SAE#4	10
STLS-202	165	93	62,9	32	M65 x 1,5	75,9	65	32	G1/4"	13
STLS-352	186	105	65,0	32	M80 x 2	88,4	80	38	G1/4"	13
▼ Double-acting										
STLD-22	112	59	42,5	25	M28 x 1,5	39,4	33	10	G1/8"	10
STLD-52	135	69	49,6	25	M35 x 1,5	47,5	38	16	G1/8"	10
STLD-92	143	80	55,1	30	M48 x 1,5	62,5	48	25	G1/4"	13
STLD-121	171	86	55,4	25	1.875-16 UNF	60,5	51	22	SAE#4	10
STLD-202	165	93	62,9	32	M65 x 1,5	75,9	65	32	G1/4"	13
STLD-352	186	105	65,0	32	M80 x 2	88,4	80	38	G1/4"	13

Note: Dimensions shown with standard clamp arm.



**A** Installation dimensions in mm

Clamping <sup>1)</sup> Force kN	Fixture hole thread size D
2,2	M28 x 1,5
5,6	M35 x 1,5
9,0	M48 x 1,5
11,6	1.875-16 UNF
18,7	M65 x 1,5
33,8	M80 x 2

<sup>1)</sup> With standard clamp arm.

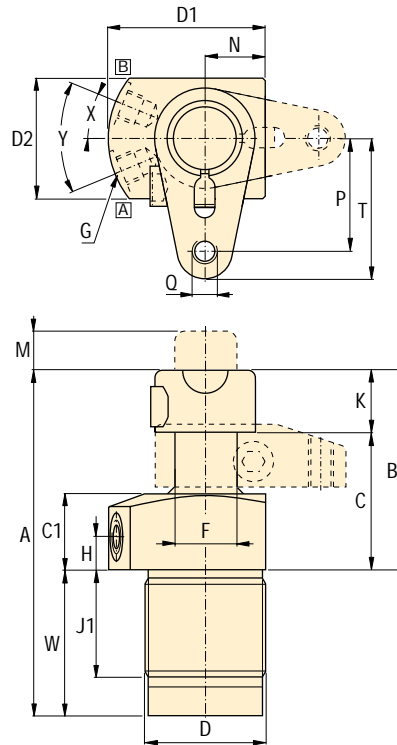
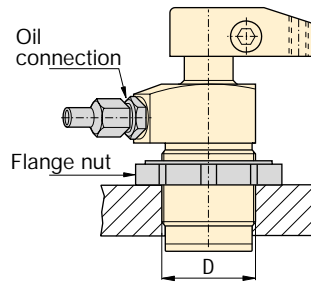

**A** = Clamping  
**B** = Unclamping (venting)

Force: 2,1 - 33,8 kN

Stroke: 16,5 - 30,0 mm

Pressure: 35 - 350 bar

- E** Cilindros giratorios
- F** Vérins de bridage pivotants
- D** Schwenkspannzylinder

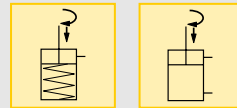

**B** Options

Clamp arms  [24](#)

Work supports  [28](#)

Collet-Lok® swing cylinders  [22](#)

Accessories  [72](#)

Sequence valves  [92](#)

**!** Important

Single-acting cylinders can be vented through the manifold port.

In case there is a risk of machining coolants and debris being inhaled via the breather vent, it is recommended to pipe this port to an area outside the fixture that is protected from machining coolants and debris.

Do not exceed maximum flow rates.

	J1	K	M	N	P	Q	T	W	X	Y		Right turning models
											kg	
												Single-acting ▼
	53,5	16	-	15,5	24	M6 x 1	31	53,5	25°	-	0,5	STRS-22
	66,4	19	-	19,1	40	M8 x 1,25	48	66,4	25°	50°	1,1	STRS-52
	43	25	15,5	23,9	45	M10 x 1,5	56	63,0	22,5°	45°	2,0	STRS-92
	85,8	30	-	25,4	51	.375-16 UNC	62	85,8	25°	50°	1,6	STRS-121
	55	30	23,6	32,5	55	M12 x 1,75	70	71,9	22,5°	45°	3,2	STRS-202
	65	40	27,9	39,9	68	M16 x 2	83	81,5	22,5°	45°	5,5	STRS-352
												Double-acting ▼
	53	16	-	15,5	24	M6 x 1	31	53,5	25°	50°	0,5	STRD-22
	66	19	-	19,1	40	M8 x 1,25	48	66,4	25°	50°	1,1	STRD-52
	43	25	-	23,9	45	M10 x 1,5	56	63,0	22,5°	45°	2,0	STRD-92
	85,8	30	-	25,4	51	.375-16 UNC	62	85,8	25°	50°	1,6	STRD-121
	55	30	-	32,5	55	M12 x 1,75	70	71,9	22,5°	45°	3,5	STRD-202
	65	40	-	39,9	68	M16 x 2	83	81,5	22,5°	45°	5,5	STRD-352

# Swing cylinders - Cartridge models

Shown: SCRD-122, SCRD-52



## SC series

Enerpac cartridge swing cylinders are designed for integrated manifold mounting. This eliminates the need for fittings and tubing on the fixture.

Cartridge swing cylinders simplify mounting and optimize clamping effectiveness.

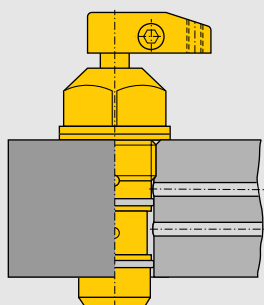

Hydraulic fixture with components on two faces for more efficient production.



## Eliminates the need for tubing and fittings

...cylinders can be designed into narrow fixture plates as thru-hole mounting is fully functional

- Minimal space required on fixture
- Can be completely recessed in fixture
- External plumbing not required
- Allows close positioning of adjoining units

Enerpac compact design cartridge model swing cylinders used in conjunction with a cartridge model work support in a typical clamping application.

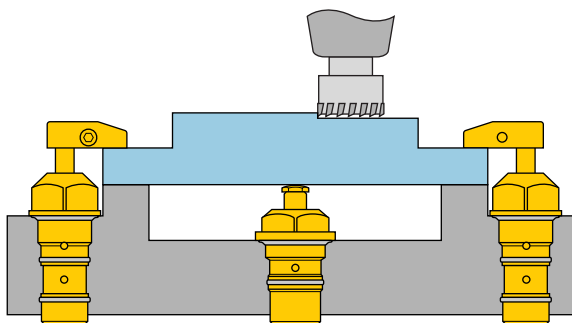

## Product selection

Clamping force <sup>1)</sup>	Stroke		Left turning	Right turning	Cylinder effective area		Oil capacity		Max. oil flow <sup>1)</sup>	Standard clamp arm Sold separately □ 24 ▶
	kN	mm			cm <sup>2</sup>	cm <sup>3</sup>				
	Clamp.	Total			Un-clamp	Clamp	Un-clamp	Clamp		
▼ Single-acting			Model number <sup>2)</sup>							
2,1	8	16,5	SCLS-22	SCRS-22	0,77	-	1,31	-	0,2	CAS-22
4,9	10	22,6	SCLS-52	SCRS-52	1,81	-	4,09	-	0,4	CAS-52
10,7	13	28,4	SCLS-122	SCRS-122	4,06	-	11,47	-	1,6	CAS-121
▼ Double-acting			Model number <sup>2)</sup>							
2,2	8	16,5	SCLD-22	SCRD-22	0,77	1,55	1,31	2,49	0,2	CAS-22
5,6	10	22,6	SCLD-52	SCRD-52	1,81	3,81	4,09	8,52	0,4	CAS-52
11,6	13	28,4	SCLD-122	SCRD-122	4,06	7,94	11,47	22,94	1,6	CAS-121

<sup>1)</sup> With standard clamp arm. Clamp arms are sold separately (□ 10, 24). Clamping forces for single-acting models are reduced in order to overcome return spring force.

<sup>2)</sup> For models with straight plunger movement, replace L or R with S.

## Dimensions in mm [D]

Left turning models	A	B	C	C1	D1	D2	E	F
					∅	∅	hexagon	
▼ Single-acting								
SCLS-22	112,0	55	39,4	21	38,1	25,4	35,1	10
SCLS-52	134,9	76	57,1	32	57,2	34,8	50,8	16
SCLS-122	171,5	94	63,5	34	76,2	57,2	69,9	22
▼ Double-acting								
SCLD-22	112,0	55	39,4	21	38,1	25,4	35,1	10
SCLD-52	134,9	76	57,1	32	57,2	34,8	50,8	16
SCLD-122	171,5	94	63,5	34	76,2	57,2	69,9	22

Note: Dimensions shown with standard clamp arm.



**A** Installation dimensions  
in mm

**-22 models**

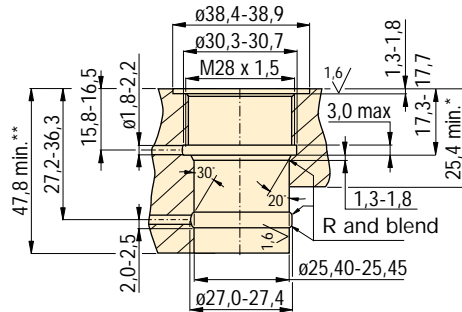

**-52 models**

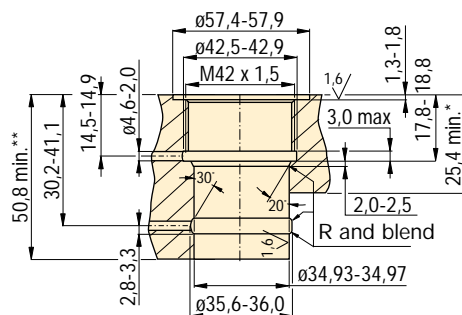

**-122 models**

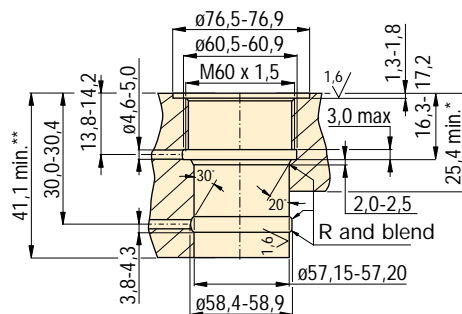

\* Minimum plate height for single-acting models.  
\*\* Minimum plate height for double-acting models.

**-22, 52, 122 models**

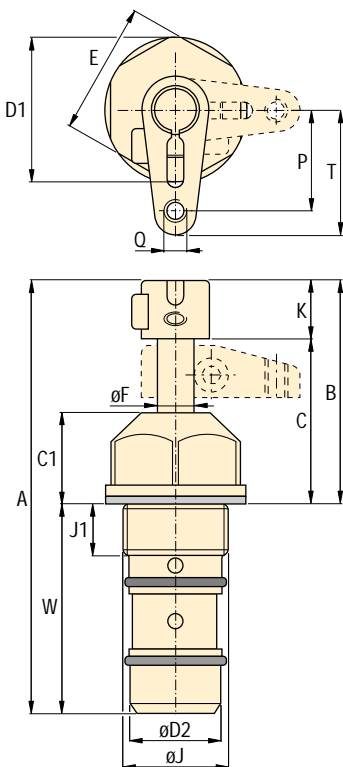

- Force: 2,1- 11,6 kN
- Stroke: 16,5 - 28,4 mm
- Pressure: 35 - 350 bar

- E** Cilindros giratorios
- F** Vérins de bridage pivotants
- D** Schwenkspannzylinder

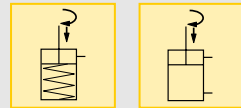

**B** Options

- Clamp arms  [24](#)
- Work supports  [28](#)
- Collet-Lok® swing cylinders  [22](#)
- Accessories  [72](#)
- Sequence valves  [92](#)

**!** Important

In case there is a risk of machining coolants and debris being inhaled via the breather vent, it is recommended to pipe this port to an area outside the fixture that is protected from machining coolants and debris.

Do not exceed maximum flow rates.

	J	J1	K	P	Q	T	W		Right turning models	
	mm								kg	
	M28 x 1,5	15,0	16	24	M6 x 1	31	56,6	0,5	Single-acting ▼	
	M42 x 1,5	16,8	19	40	M8 x 1,25	48	58,7	0,9	SCRS-22	
	M60 x 1,5	15,7	30	51	.375-16 UNC	62	74,6	2,5	SCRS-122	
	M28 x 1,5	15,0	16	24	M6 x 1	31	56,6	0,5	Double-acting ▼	
	M42 x 1,5	16,8	19	40	M8 x 1,25	48	58,7	0,9	SCRD-22	
	M60 x 1,5	15,7	30	51	.375-16 UNC	62	74,6	2,5	SCRD-122	

# Swing cylinders - Collet-Lok® design

Shown: MPFR-100, MPTR-100



## MP series

Enerpac Collet-Lok® cylinders are designed to mechanically hold the workpiece after hydraulic pressure is removed. Clamping capacities range from 4,4 kN to 37,8 kN.

BSPB oil connection

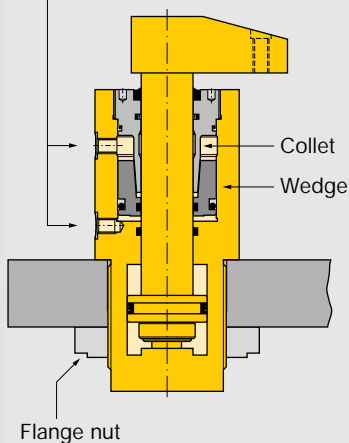

Hydraulic pressure pushes the collet up a wedge, locking the plunger in the clamping position.

■ Lower flange Collet-Lok® swing cylinder mounted on a pallet.



## Ideal when live hydraulics are not available

...clamping is maintained mechanically so live hydraulics are not required during the machining cycle

- Double acting Collet-Lok® action allows fully automated operation
- Additional level of safety since live hydraulics are not required
- Collet-Lok® swing cylinders can either be mounted by the flange, or threaded into the fixture

## Product selection

Clamping force <sup>1)</sup> kN	Stroke mm		Left turning 90° 	Right turning 90° 	Cylinder effective area cm <sup>2</sup>		Oil capacity cm <sup>3</sup>		Max. oil flow <sup>1)</sup> l/min	Standard clamp arm Sold separately □ 24 ▶
	Clamp.	Total			Clamp	Un-clamp	Clamp	Un-clamp		
▼ Lower flange										
			Model number							
4,4	8	24	MPFL-50	MPFR-50	1,61	4,58	3,93	10,98	2	MA-540
8,9	12	28	MPFL-100	MPFR-100	3,22	7,16	9,01	19,99	5	MA-1050
37,8	10	42	MPFL-300	MPFR-300	13,23	22,25	55,71	93,41	10	MA-3070
▼ Threaded body										
			Model number							
8,9	12	28	MPTL-100	MPTR-100	3,22	7,16	9,01	19,99	5	MA-1050
37,8	10	42	MPTL-300	MPTR-300	13,23	22,25	55,72	93,41	10	MA-3070

<sup>1)</sup> Using standard clamp arm.  
Clamp arms are sold separately (□ 10, 24).

Note: - Call Enerpac for models with imperial thread and SAE port connections.  
- Minimum working pressure for Collet-Lok® system is 100 bar.

## Collet-Lok® sequence

**Step 1**

Pressurize port #1.  
Plunger turns 90° and clamps part.

**Step 2**

Keep port #1 pressurized.  
Pressurize port #2.  
Plunger will be locked in clamped position.

**Step 3**

Depressurize port #1 and #2.  
Uncouple cylinder from hydraulic power source.  
Part will be held in place.

**Step 4**

Pressurize port #3.  
Plunger will be unlocked and the clamp force released.

**Step 5**

Keep port #3 pressurized.  
Pressurize port #4.  
Plunger will extend and turn to its original position.

## Product dimensions in mm [⌀]

Left turning models	A	B	C	C1	D ∅	D1 ∅	F ∅	H1	H2	H3
▼ Lower flange										
MPFL-50	201	177	171	25	58	85	19	10	12,7	-
MPFL-100	223	195	193	25	68	100	22	10	12,7	-
MPFL-300	321	280	275	25	90	132	35	11	12,7	-
▼ Threaded body										
MPTL-100	213	185	121	90	M48 x 1,5	70	22	31	66,8	75,2
MPTL-300	310	268	163	115	M80 x 2	93	35	38	91,4	100,6

Note: Dimensions shown with standard clamp arm.



**A** Installation dimensions  
in mm

Clamping force <sup>1)</sup> kN	Fixture hole øD3	Mounting Thread J	Minimum depth J2
<b>▼ Lowerflange</b>			
4,4	58,4 ±0,3	M6 x 1	18
8,9	68,6 ±0,3	M8 x 1,25	19
37,8	90,5 ±0,3	M10 x 1,5	19
<b>▼ Threaded body</b>			
8,9	M48 x 1,5	-	-
37,8	M80 x 2	-	-

<sup>1)</sup> With standard clamp arm.

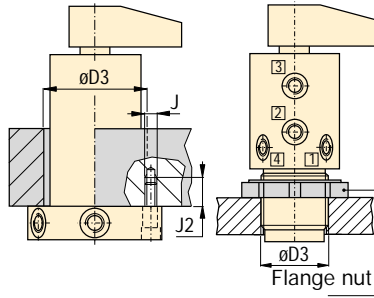

**Oil port functions**

- 1 90° Rotation and Clamp
- 2 Locks system
- 3 Unlocks system
- 4 Unclamp and 90° rotation

Force: 4,4 - 37,8 kN
Stroke: 24 - 42 mm
Pressure: 100 - 350 bar

- E** Cilindros giratorios
- F** Vérins de bridage pivotants
- D** Schwenkspannzylinder

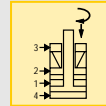

**MPF models**

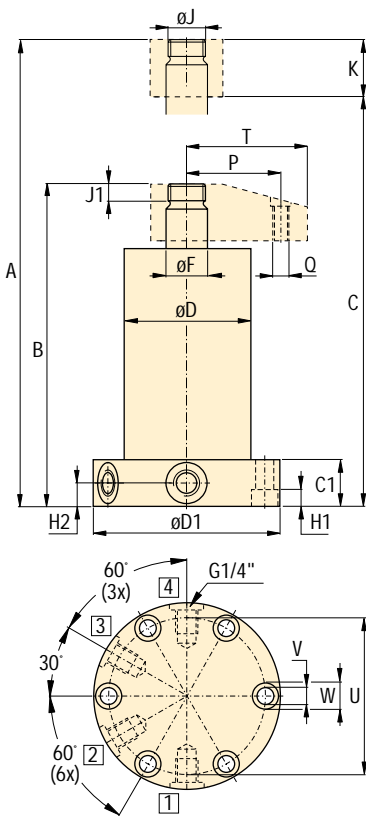

**MPT models**

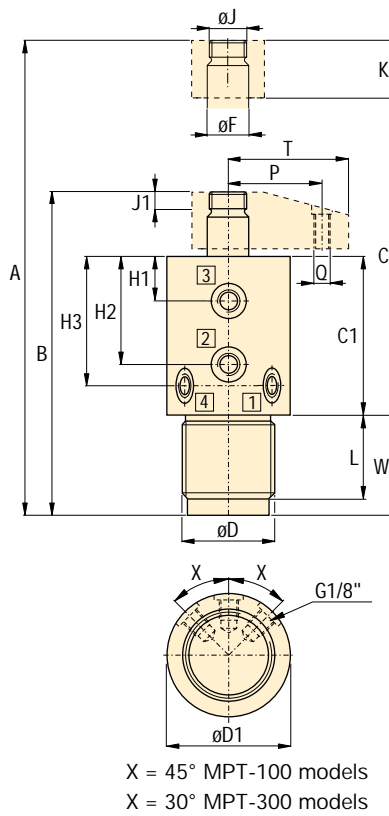

X = 45° MPT-100 models  
X = 30° MPT-300 models

**FMS** Flexible Machining Systems  
See Yellow Pages (136)

**Options**

- Clamp arms** 24 ▶
- Positive locking work supports** 34 ▶
- Positive clamping cylinders** 66 ▶
- Auto couplers** 100 ▶
- Sequence valves** 92 ▶
- Accessories** 72 ▶

	J	J1	K	L	P	Q	T	U	V	W	kg	Right turning models
<b>Lower flange ▼</b>												
M16x1,5	8	30	-	40	M8x1,25	54	70	9	14	2,3	MPFR-50	
M20x1,5	9	30	-	50	M10x1,5	64	84	9	14	3,5	MPFR-100	
M33x2	10	47	-	70	M16x2	93	112	11	14	12,0	MPFR-300	
<b>Threaded body ▼</b>												
M20x1,5	9	30	41	50	M10x1,5	64	-	-	30	3,0	MPTR-100	
M33x2	10	47	85	70	M16x2	93	-	-	30	11,0	MPTR-300	

**Important**

For proper application, clamp forces, pressures and timing consult Enerpac for support.

# Clamp arms *for swing cylinders*

Shown: CAL-122, CAS-121



9B-045

▶ Clamp arms are used to transmit the force generated by the swing cylinder to the workpiece. Enerpac's patented clamp arm design attaches to the hydraulic swing cylinder, allowing parts to be clamped at various distances from the hydraulic cylinder. Clamp arms are available in a variety of lengths, or you can use custom machining dimensions to create your own clamp arm configuration.

■ *Hydraulic fixture with swing cylinders and standard clamp arms on two faces for more efficient production.*



02-002

## Patented Design

- Easy and precise location of the clamp arm in any position
- Arm can be easily installed and fastened while the cylinder is mounted in the fixture to allow exact arm positioning
- Vise not required for fastening arms

## Pressure vs clamping force

The use of different length clamp arms requires reduction in applied pressure and resulting clamp force. The diagrams on page 10 below show this relationship.

## Product selection

Clamp arm length L mm min. - max.	Clamping force F <sub>T</sub> kN max. - min.	For Swing Cylinder Model	Clamp Arm Model Number	See Diagrams on page	Technical Specifications on page
<b>▼ Clamp arms for Swing Cylinders SU, SL, ST and SC series</b>					
25 - 78	2,2 - 0,5	22	CAS-22, CAL-22	11	25
40 - 130	5,6 - 1,0	52	CAS-52, CAL-52	11	25
45 - 155	9,0 - 2,2	92	CAS-92, CAL-92	11	25
51 - 157	11,6 - 2,0	121, 122	CAS-121, CAL-122	11	25
55 - 173	18,7 - 4,0	202	CAS-202, CAL-202	11	25
68 - 175	33,8 - 9,0	352	CAS-352, CAL-352	11	25
<b>▼ Clamp arms for Collet-Lok® Swing Cylinders MP series</b>					
40 - 100	4,1 - 1,1	50	MA-540	11	25
50 - 125	8,9 - 2,5	100	MA-1050	11	25
70 - 160	37,8 - 9,5	300	MA-3070	11	25
<b>▼ Pivoting T-arms for SU, SL, ST and SC series swing cylinders</b>					
152 <sup>1)</sup>	2 x 2,8	52	CAC-52, CAPT-52	11	26
203 <sup>1)</sup>	2 x 4,5	92	CAC-92, CAPT-92	11	26
203 <sup>1)</sup>	2 x 5,8	122	CAC-122, CAPT-122	11	26
203 <sup>1)</sup>	2 x 9,3	202	CAC-202, CAPT-202	11	26
228 <sup>1)</sup>	2 x 16,9	352	CAC-352, CAPT-352	11	26

<sup>1)</sup> Lmax. for T-arms.

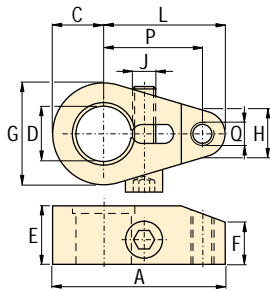
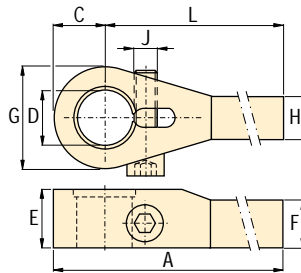
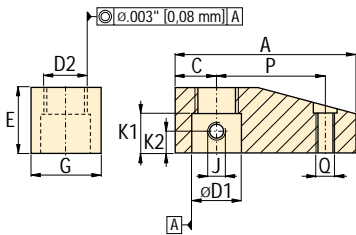
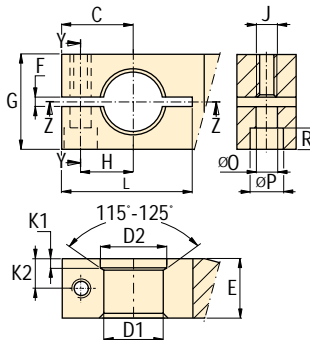
**CAS models** Standard clamp arms

**CAL models** Long clamp arms

**MA models** For Collet-Lok® Swing cylinders serie MP

**Custom design** (for SU, SL, ST and SC models only)

**Dimensions in mm**

Clamp force kN	Model number	A	C	D	E	F	G	H	J	L	P	Q	kg
----------------	--------------	---	---	---	---	---	---	---	---	---	---	---	----

**Standard clamp arms**

2,2	CAS-22	41	9,7	9,95-10,05	16	10	19	13	M6x1	31	25	M6x1	0,1
5,6	CAS-52	61	12,7	15,95-16,05	19	11	25	16	M8x1	48	40	M8x1,25	0,1
9,0	CAS-92	76	20,1	24,94-25,04	25	16	40	23	M10x1,25	56	45	M10x1,5	0,3
11,6	CAS-121	80	17,8	22,17-22,27	30	16	35	21	.375-24UNF	62	51	.375-16UN	0,5
18,7	CAS-202	94	24,1	31,93-32,03	30	21	48	30	M12x1,25	70	55	M12x1,75	0,5
33,8	CAS-352	118	35,1	37,95-38,05	40	29	70	31	M16x1,5	83	68	M16x2	1,4

**Long clamp arms**

2,2	CAL-22	92	9,7	9,95-10,05	16	10	19	11	M6x1	83	-	-	0,1
5,6	CAL-52	148	12,7	15,95-16,05	19	11	25	14	M8x1	135	-	-	0,3
9,0	CAL-92	180	20,1	24,94-25,04	25	16	40	18	M10x1,25	160	-	-	0,6
11,6	CAL-122	179	17,8	22,17-22,27	30	16	35	18	M10x1,5	162	-	-	0,7
18,7	CAL-202	202	24,1	31,93-32,03	30	21	48	25	M12x1,25	178	-	-	0,7
33,8	CAL-352	215	35,1	37,95-38,05	40	34	70	30	M16x1,5	180	-	-	1,9

Clamp force kN	Model number	A	C	D1	D2	E	G	J	K1	K2	P	Q	kg
----------------	--------------	---	---	----	----	---	---	---	----	----	---	---	----

**Clamp arms for Collet-Lok® swing cylinders**

4,4	MA-540	72	18	19,02-19,05	M16x1,5	30	32	M8x1,25	19	10	40	M8x1,25	0,5
8,9	MA-1050	83	19	22,30-22,33	M20x1,5	30	35	M8x1,25	18	10	50	M10x1,5	0,5
37,8	MA-3070	128	35	34,97-35,00	M33x2	47	59	M8x1,25	32	17	70	M16x2	2,3

Clamp force kN	C	D1 <sup>1)</sup>	D2	E	F	G	H	J	K1	K2	L	O	P	R
----------------	---	------------------	----	---	---	---	---	---	----	----	---	---	---	---

**Custom design clamp arms<sup>2)</sup>** (Recommended machining dimensions)

2,2	15,5	10,00-10,02	12,58-12,62	16	1,5-3,0	20	9,4	M6x1	3,1-3,5	8	25-28	7,0	12	2
5,6	20,1	16,00-16,03	18,47-18,51	19	1,5-3,0	30	13,5	M8x1	4,1-4,5	10	35-40	9,0	13	2
9,0	30,0	25,00-25,03	27,85-27,95	25	1,5-3,0	40	22,1	M10x1,25	3,9-4,2	12	55-60	10,0	17	2
11,6	28,4	22,24-22,27	25,46-25,55	30	1,5-3,0	35	17,8	M10x1,5	6,9-7,3	13	52-57	10,0	17	3
18,7	35,1	32,00-32,04	35,50-35,60	30	1,5-3,0	60	24,9	M12x1,25	5,1-5,5	15	62-67	13,0	19	3
33,8	39,9	38,00-38,04	41,50-41,60	40	1,5-3,0	70	30,0	M16x1,5	4,9-5,3	20	80-85	17,0	25	4

<sup>1)</sup> Surface roughness for D1 should be 1,6 micrometers.

<sup>2)</sup> Not for use with Collet-Lok® swing cylinders.

**Force:** 0,5 - 37,8 kN

**Pressure:** 35 - 350 bar

- E** Brazos de amarre
- F** Bras de bridage
- D** Spannarme

**Options**
**Gauges**

106 ▶

**Flow control valves**

96 ▶

**Important**
**Do not exceed maximum oil flow**

If flow rates are exceeded, swing cylinder indexing mechanism may be permanently damaged.

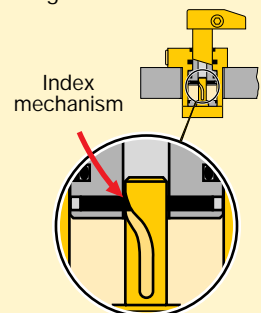

When designing custom clamp arms, the flow rates must be further reduced. This rating should be in proportion to the mass and the centre of gravity of the clamp arm.

**Example:**

*If the mass of the arm is twice that of the long arm, flow rates must be reduced by 50%.*

Shown: CAC-202, CAPT-202, CAC-352, CAPT-352



▶ The T-arm clamps two workpieces simultaneously with one swing cylinder. Enerpac recommend to use the pivoting T-arms with double-acting swing cylinders of the SU, SL, ST and SC-series.

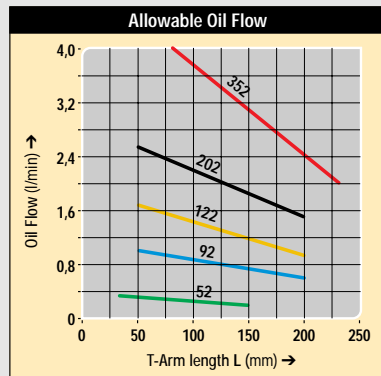

■ Two workpieces are clamped simultaneously with one double-acting swing cylinder by using the Enerpac pivoting T-arm.



## Clamping two workpieces with one cylinder

...quick and precise clamp arm positioning

- Pivoting clamp arm compensates large differences in workpiece height
- The clamp arm design allows quick random positioning
- CAC series can be installed without removing the cylinder from the fixture
- Silicone spring is compatible with all coolants and protects against contamination
- Simple design allows easy creation of your own T-arm

Force:	5,6 - 33,8 kN
Pressure:	35 - 350 bar

- Ⓔ Brazos de amarre
- Ⓕ Bras de bridage
- Ⓖ Spannarme

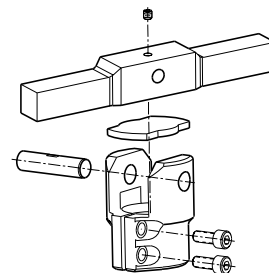

### CAC models

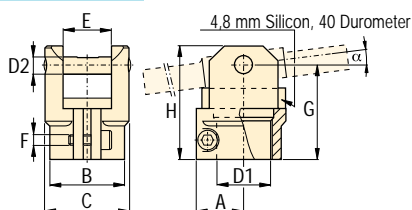

### CAPT models

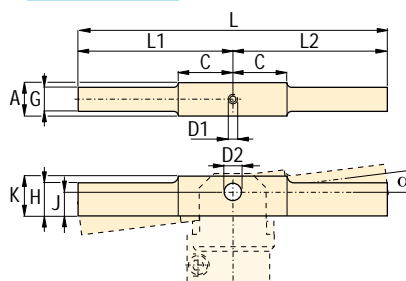

## Collars – Dimensions in mm [⊕]

Clamp. force kN	Model number	Max. Tilt Angle α	A	B	C	D1	D2	E	F	G	H	kg
5,6	CAC-52	20°	16,5	24,0	28,0	16,0	6,0	16,1	M4x0,7	32,0	40,0	0,09
9,0	CAC-92	14°	22,0	34,6	39,0	25,0	8,0	22,5	M5x0,8	43,2	52,6	0,20
11,6	CAC-122	14°	22,0	34,6	39,0	22,3	8,0	22,5	M5x0,8	43,2	52,6	0,20
18,7	CAC-202	10°	27,2	46,6	54,5	32,0	10,0	28,8	M6x1,0	51,2	63,0	0,47
33,8	CAC-352	10°	34,0	54,6	63,0	38,0	14,0	35,2	M8x1,25	63,4	79,0	0,80

## T-Arms – Dimensions in mm [⊕]

Clamp. force kN	Model number	A	C	D1*	D2	G	H	J	K	L	L1	L2	kg
5,6	CAPT-52	15,6	25,5	M3x0,5	6,02-6,12	12,7	12,7	10,0	19,0	152,4	76,2	76,2	0,27
9,0	CAPT-92	22,0	38,1	M4x0,7	8,02-8,12	18,3	18,3	15,1	22,2	203,2	101,6	101,6	0,66
11,6	CAPT-122	22,0	38,1	M4x0,7	8,02-8,12	18,3	18,3	15,1	22,2	203,2	101,6	101,6	0,66
18,7	CAPT-202	28,3	31,8	M6x1,0	10,02-10,12	22,0	22,0	16,2	28,6	203,2	101,6	101,6	0,96
33,8	CAPT-352	34,7	25,0	M6x1,0	14,02-14,12	30,0	30,0	18,4	34,8	228,6	114,3	114,3	1,78

\* Note: D1 equals set screw thread size. Set screw must be long enough to secure the pivot pin.

## Installation dimensions in mm [⊕]

Clamping force kN	Swing cyl. and T-arm model	SU-series C	SL-series C	ST-series C	SC-series C
5,6	52	73,7	139,7	73,7	81,0
9,0	92	79,5	155,5	84,6	-
11,6	122	90,2	176,0	90,2	98,3
18,7	202	90,7	177,5	90,7	-
33,8	352	102,6	199,1	109,5	-

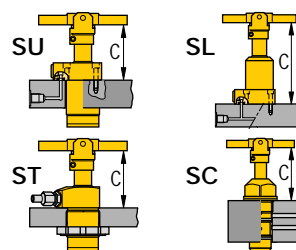

Force:	6,1 - 19,5 kN
Stroke:	6,4 - 10,9 mm
Pressure:	80 - 170 bar

- (E) Cilindros giratorios
- (F) Verins de bridage pivotants
- (D) Schwenkspannzylinder

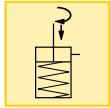

## Options

**Fittings**



110 ▶

**Hoses and couplers**



108 ▶

**Flow control valves**



96 ▶

**Gauges**



106 ▶

## Adjustable clamping stroke

...turns clockwise or counter clockwise

- Adjustable bolt in clamp arm for clamping stroke adjustment
- Low profile, ideal for limited space applications
- Quick swing action allows clamp arm to swing free of cutter and reclamp after it has passed
- 94-100° clamp arm swing arc

ASC-30, -100

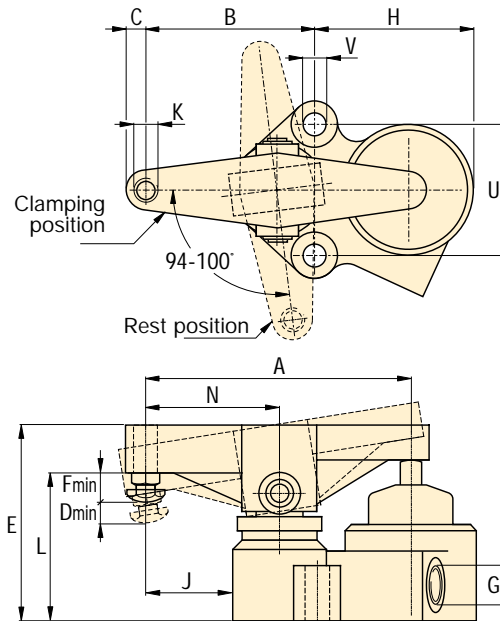

Shown: ASC-30



## ASC series

Clamping arm rotates 97° clockwise or counter clockwise (requires easily changed rotation spring) to position itself over the workpiece. Then, a vertical plunger exerts an upward thrust on the back end of the swing arm providing a powerful downward pressure to clamp the workpiece.

## Selection chart

Cylinder capacity	Stroke	Model number	Operating pressure	Cylinder effective area	Oil Capacity	Max. oil flow	
kN	mm		bar	cm <sup>2</sup>	cm <sup>3</sup>	l/min	kg
6,1	6,4	ASC-30	80-170	3,5	4,9	1,9	2,7
19,5	10,9	ASC-100	80-170	11,4	20,0	1,9	8,2

## Product dimensions in mm [ ]

Model number	A	B	C	D	E	F	G	H	J	K	L	N	U	V
	NPT						UN						∅	
ASC-30	127,0	85,9	12,7	6,4	88,9	19,1	.125-27	69,9	41,4	.500-13	69,9	63,5	63,5	10,4
ASC-100	177,8	114,3	13,5	10,9	133,4	18,5	.125-27	108	57,2	.500-13	101,6	88,9	88,9	16,0

View of a machining fixture with ASC-30 clamping cylinders.



# Work supports *Application & selection*

Shown: MPFS-100, WFL-112, WFC-72, WFL-442



▶ The Enerpac work support is a hydraulic means of positively supporting the workpiece to minimize deflections.

The work support automatically adjusts to the contour of the workpiece, and then locks in position. This support then adds rigidity to the fixtured component to minimize machining variations.

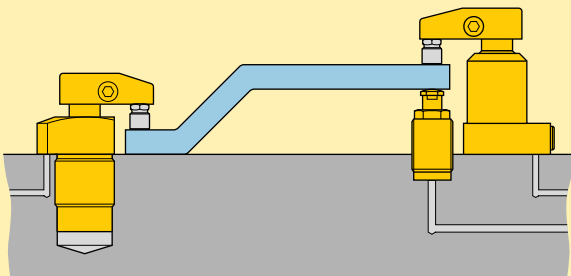

■ Lower flange work supports, placed close to the machining area to minimize deflection of the workpiece.

## Wide range of sizes and types to efficiently support workpiece

- Low pressure lock-up capability enables the use of machine tool hydraulic systems
- High rated support capacities allow for more compact fixture design
- Corrosion resistant materials, compatible with most coolants and environments
- Threaded and manifold air vent ports allow fixturing that prevents coolants from being drawn into the system
- Minimized deflection increases machining accuracy
- Multiple mounting configurations allow design flexibility
- Collet-Lok® positive locking models:  
Hydraulic actuation / mechanical holding allows for palletized systems which do not permit live hydraulics

## i Select your work support method:

### WF series, Hydraulic advance

- Retracted plunger allows unobstructed workpiece loading.
- Internal hydraulic plunger advances allowing external plunger to advance under spring load. Bronze sleeve squeezes and holds plunger in fixed position.

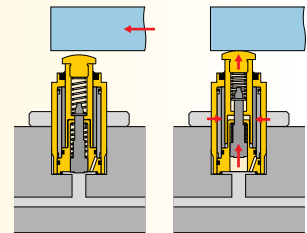

□30 ▶

### WS series, Spring advance

- Workpiece weight compresses the spring of the extended plunger.
- When pressurized, the internal bronze sleeve squeezes and holds the plunger in fixed position.
- Can be operated as air advance.

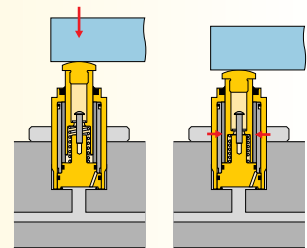

□32 ▶

### MP series, Collet-Lok® positive locking

- Unique in the industry. Allows the work support to maintain support after pressure has been removed.
- Extremely low deflections due to the structural design of the collet system.
- Low lockup pressure.

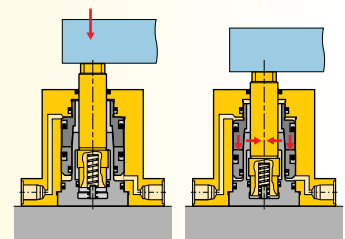

□34 ▶





## **i** Select your mounting method:

### Manifold mount

- Does not require external plumbing
- Compact design, when space is at a premium
- Internal plunger thread for optional contacts

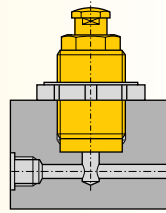

### Threaded body

- Ability to adjust height
- Plumbed from either side or bottom
- Internal plunger thread for optional contacts

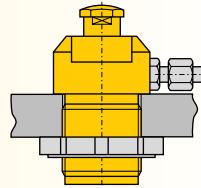

### Lower flange

- Plumbed directly or manifold mounted
- No fixture hole required
- Easy to assemble or disassemble
- Internal plunger thread for optional contacts

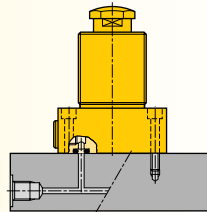

### Cartridge style

- Does not require external plumbing
- Allows close clustering of work supports
- Compact design, when space is at a premium
- Internal plunger thread for optional contacts

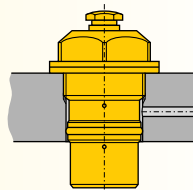

## **globe** Product selection

Maximum support force	Stroke	Manifold mount	Threaded body	Lower flange	Cartridge style
kN	mm				
<b>▼ Hydraulic advance</b>					
		Model number			
7,3	9,7	WFM-72	WFT-72	-	WFC-72
11,1	9,7	-	-	WFL-112	WFC-112
22,2	10,4	-	-	WFL-222	WFC-222
33,4	13,5	-	-	WFL-332	-
44,5	16,5	-	-	WFL-442	-
<b>▼ Spring advance</b>					
		Model number			
7,3	9,7	WSM-72	WST-72	-	WSC-72
11,1	9,7	-	-	WSL-112	WSC-112
22,2	10,4	-	-	WSL-222	WSC-222
33,4	13,5	-	-	WSL-332	-
44,5	16,5	-	-	WSL-442	-
<b>▼ Collet-Lok®</b>					
		Model number			
8,9	9,9	-	MPTS-100	MPFS-100	-
17,8	9,9	-	MPTS-200	MPFS-200	-

Force: 7,3 - 44,5 kN

Stroke: 9,7 - 16,5 mm

Pressure: 50 - 350 bar

- E** Cilindros de soporte
- F** Vérin anti-vibreur
- D** Abstützylinder

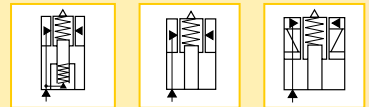

## **globe** Options

### Swing cylinders

12 ▶



### Accessories

72 ▶



### In line filters

109 ▶



### Sequence valves MVP5

92 ▶



## **Warning** Important

### Warning!

Support force and clamping force must be matched. Support force should be at least 150% of clamping force.

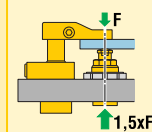

Do not exceed maximum flow rates to avoid premature lockup.

Always center load over work support.

