

# Features SL300

Safe Work Load Stage 1:	750 kN	(169 kips)
Safe Work Load Stage 2:	500 kN	(112 kips)
Self Weight (incl. oil):	3250 kg	(7165 lbs)

D

C

B

A

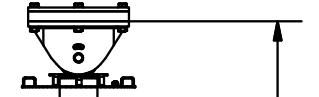
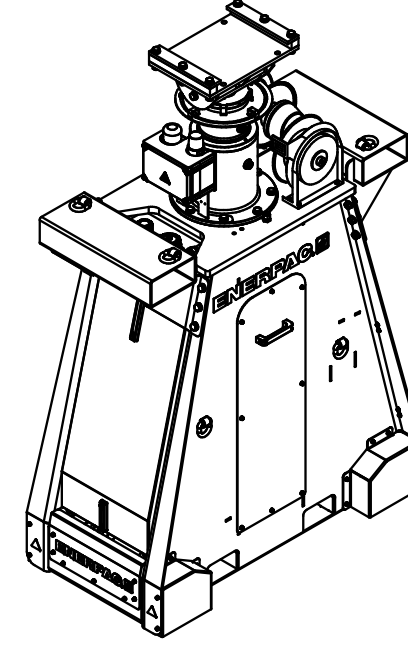
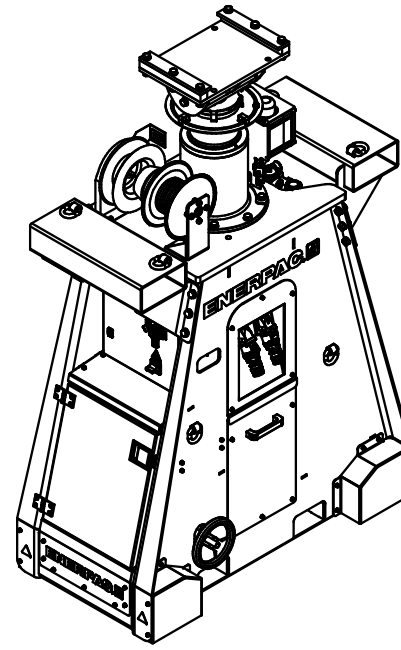
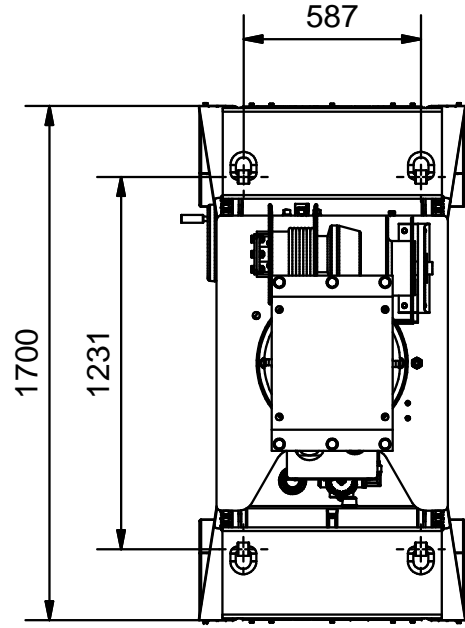
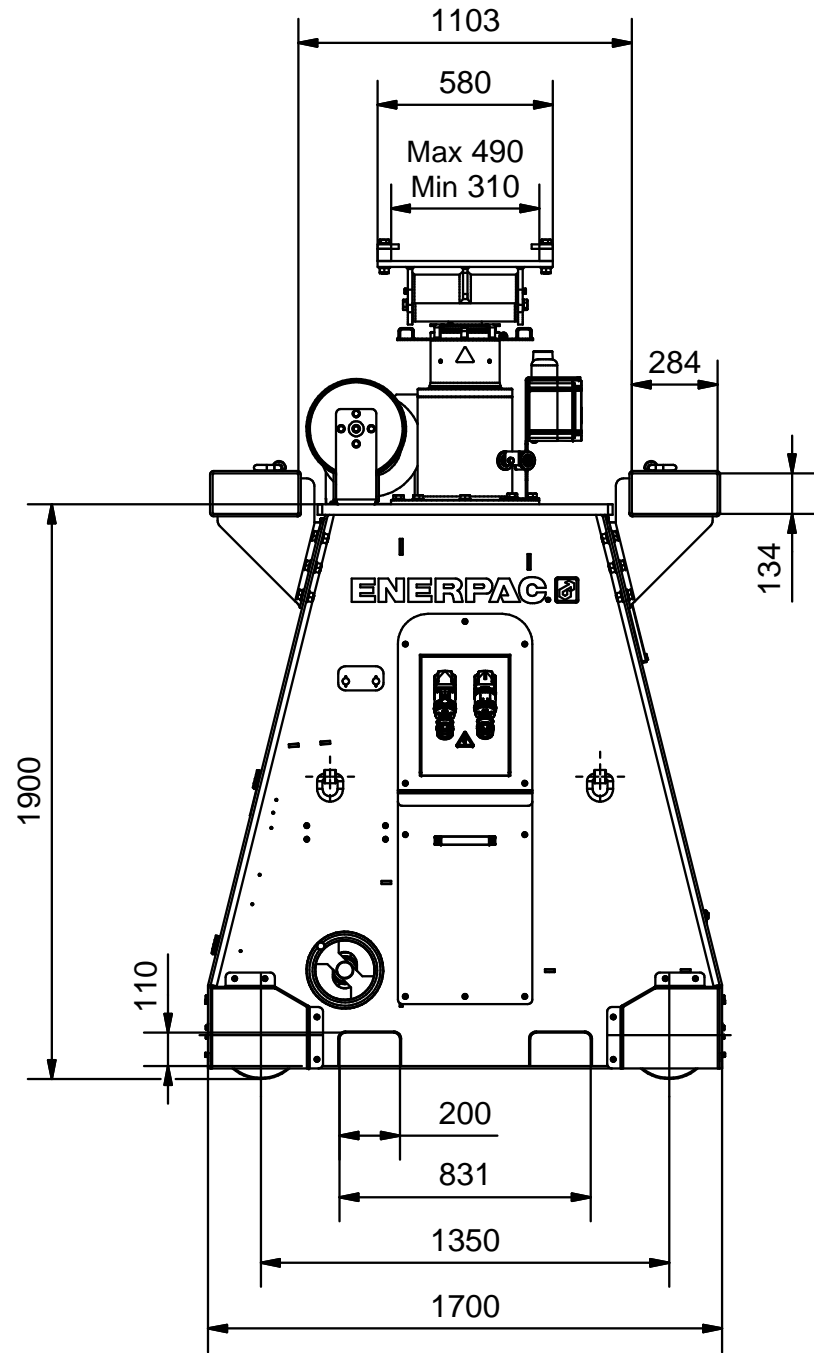

D

C

B

A

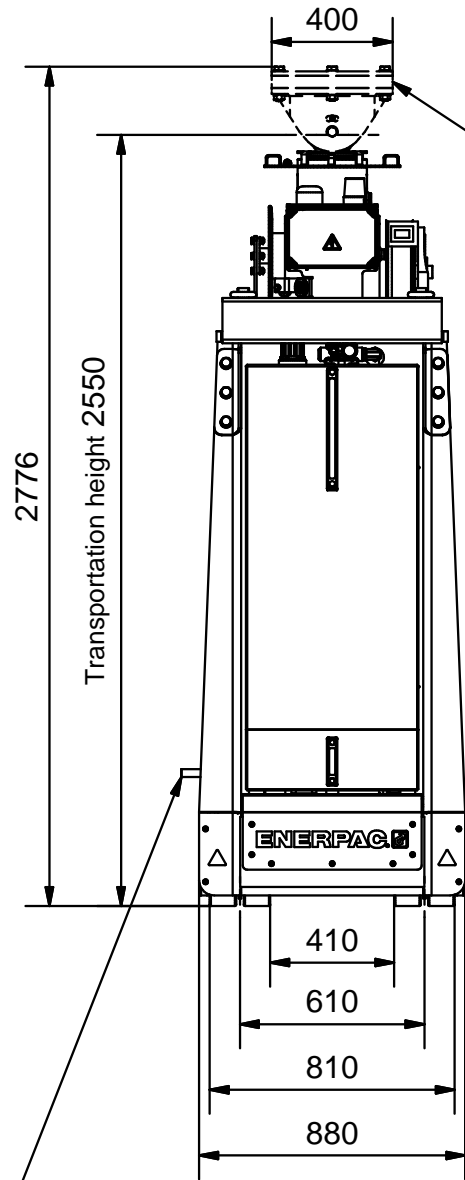

Remove swivel for transportation in high cube container

Handwheel lever foldable

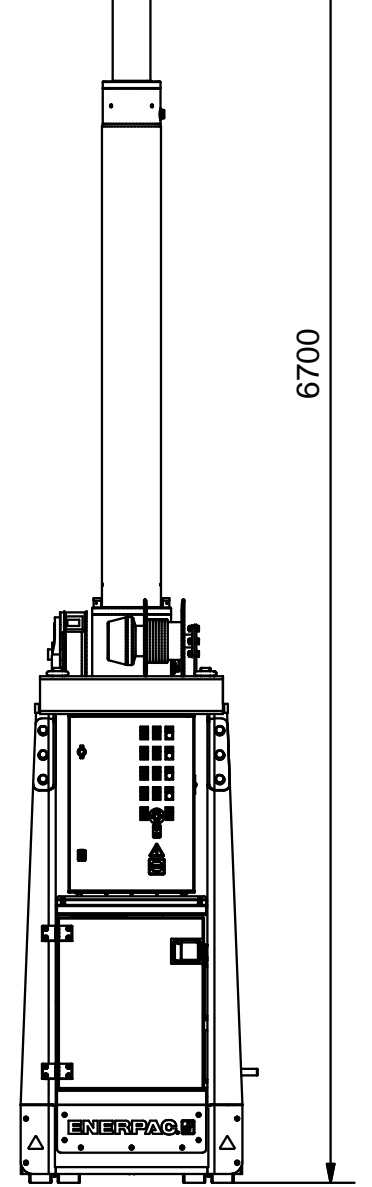
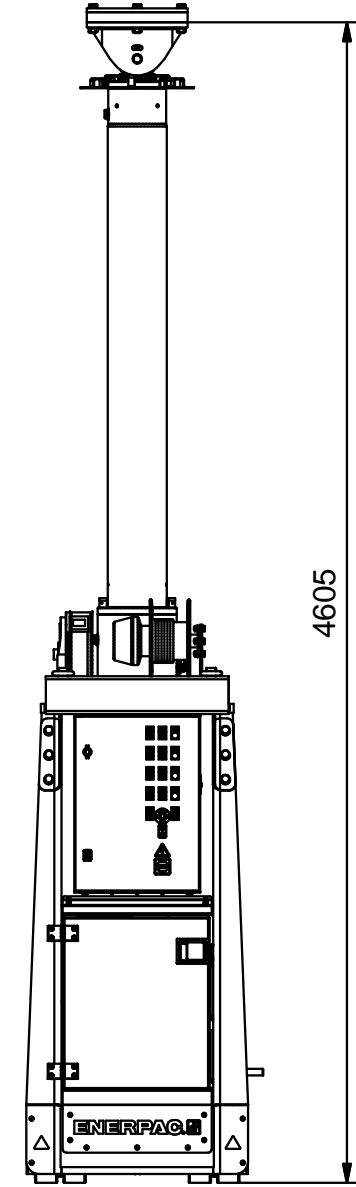
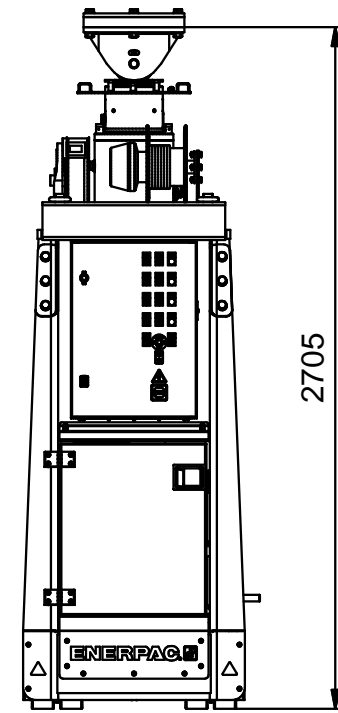

OPAAALSTRAAT 44, 7554 TS HENGELO HOLLAND  
PO BOX 421, 7550 AK HENGELO HOLLAND  
TELEPHONE 074-2422045 FACSIMILE 074-2430338



3rd ANGLE PROJECTION

Model Number:

SL300

Drawing Number:

03517.50.00.00

Main Assembly Number:

03517.01.00.00

REV.: 0

DATE: 20-10-16

SCALE: 1:25

FORM: A3

6

5

4

3

2

1